

Camping & Yacht

DynaCook X2 mini

DynaCook X2 DOMINO

Warranty card / Installation and use manual

EN

Attachment no. 1 to the Terms of Warranty

DEAR SIR OR MADAM!
WITH CONSIDERATION OF YOUR SAFETY AND THE WARRANTY RIGHTS,
PLEASE CAREFULLY READ THE INFORMATION PRESENTED BELOW

CONNECTION CERTIFICATE

Ceramic DynaCook cooktop



The Connection Certificate is filled out and signed by an authorised installation technician holding appropriate and valid certification. In order for the warranty covering the purchased cooktop to be effective, the Connection Certificate must be filled out and signed.



In order to ensure your safety, avoid contamination of the internal gas system of the cooktop, and avoid damage and/or leakiness of the cooktop, the manufacturer has secured the gas connector of the DynaCook ceramic gas cooktop with a cap/seal.

The only individual authorised to remove the cap/seal is the individual connecting the cooktop to the gas supply system, who must hold appropriate and valid certification.

The cap/seal must be removed before the cooktop is connected to the gas supply system. This fact must be confirmed by the installation technician in this Connection Certificate. If the installation technician should determine establish the cap/seal of the connector to be missing, this fact must be recorded in this Connection Certificate.

The manufacturer is not held liable for any damage to the ceramic cooktop or any losses resulting from removal of the gas connection cap/seal or from installation of the cooktop by an individual without appropriate and valid certification.

Installed gas type	G30 (3B/P) G31 (3P)
Gas Pressure [mbar]	30 mbar
(mark with X as appropriate)	

Was the gas connector in the cooktop secured with a cap/seal? (mark as appropriate)	YES	NO
--	-----	----

Date of installation	
License number of the installation technician	
Stamp and signature of the installation technician	

WARRANTY, SERVICING

Warranty

Warranty services are provided in accordance with effective provisions pursuant to the entries in the Warranty Card, which is attached to this documentation.

Servicing

In the event of any problems with your DynaCook, you can count on the DynaCook Service Centre for quick and professional assistance. We want to guarantee full convenience in use of the DynaCook to everyone who placed their trust in the Dynaxo brand.

tel. +48 606 649 549

e-mail: serwis@dynaxo.pl

www.dynacook.pl

<https://www.dynacook.pl/en/support/>

Warranty Card

Ceramic DynaCook cooktop

The warranty card is valid with a document confirming the date of initial purchase of the Product

TERMS OF WARRANTY

The **Customer** must read this document with care, as it shall be assumed that the Customer has understood and accepted the terms of this Warranty and read the Instruction and Operation Manual constituting Attachment no. 2 to the Terms of Warranty in the event any claims filed in accordance with this Warranty.

Dynaxo Spółka z ograniczoną odpowiedzialnością with its registered seat in Popowo 2A, 64-510 Wronki, POLAND, entered in the register of entrepreneurs of the National Court Register under the number KRS 0000163601, NIP (taxpayer identification number): 763-00-16-420, hereinafter **Guarantor**, hereby grants a warranty covering the DynaCook ceramic gas cooktop, hereinafter **Product**, with serial number corresponding to that entered on the first page of this Instruction and Operation Manual and the rating plate found on the lower shield of the DynaCook, to the Customer under the following conditions:

1. This Warranty grants specific rights and authorisations entitled to the Customer towards the Guarantor.
2. In order to ensure that the Product is used safely and under the penalty of voiding warranty rights, the Guarantor unconditionally requires that the Product be **installed in the location of its use by a certified gas installation technician in accordance with the Instruction and Operation Manual (Attachment no. 2 to the Terms of Warranty)**. The costs of installation of the Product in the location of its use are covered by the Customer. In relation to this requirement, an appropriate entry must be made in the appropriate section of this Warranty Card in the Product's Connection Certificate, which constitutes Attachment no. 1 to the Terms of Warranty.
3. **The product can be used for purposes of cooking food in private households and on boats, motor homes and caravans only.**
4. The Product comes with a **24-month Warranty**.
5. The warranty commences on the date of the Product's purchase by the end user (Customer).
6. The Guarantor asserts that the Product shall be free of material and design defects from the initial purchase by the end user in **countries of the European Economic Area ("Area")** as long as it is used according to the instruction and installation manual constituting Attachment no. 2 to this Warranty.
7. Flaws in the Product shall be removed within 14 business days counted from the date on which the appropriate complaint is filed and the Product is made available to the Guarantor. The Warranty is subject to extension over the time corresponding to that between the date on which the appropriate complaint is filed and the Product is made available to the Guarantor and the date of release of the flaw-free product back to the Customer. In special and legitimate instances, a complaint may be processed within 21 business days.
8. In the event of warranty claims, the Guarantor shall either replace or repair the Product or any of its parts covered by the warranty – at the Customer's discretion – with brand new parts or parts refurbished by the manufacturer. If the Guarantor should decide to use parts refurbished by the manufacturer, said parts shall offer technical characteristics and quality corresponding to those of brand new products.
9. If the Guarantor's service point should decide that the Product cannot be repaired or that a single major element of the Product has undergone repeated repairs, the Customer has the right to have the Product replaced with a new one free of flaws. Information concerning the replacement in question can be obtained from the Guarantor's service point.
10. All parts replaced under this Warranty shall become the property of the Guarantor.
11. If the repair of the Product must be carried out in **Service Centre of the Guarantor**, Customer ships the Product at the expense of the Guarantor to the following address: **Dynaxo Sp. z o.o., Popowo 2a, 64-510 Wronki, POLAND**. Following repairs, the Product is returned to the Customer at the expense of the Guarantor.
12. If the Product is subject to repairs in the location of its use, its owner should provide appropriate space and conditions for the repairs in question to the service representatives of the Guarantor.

13. Warranty repairs do not cover the actions specified in the Installation and Operation Manual of the Product, which are the responsibility of the user and must be performed with the user's own means and at the user's own expense.
14. **Acceptance of complaints for processing is conditioned by delivery of the appropriate notice in writing** by <https://www.dynacook.pl/en/support/>, or e-mail to the address of serwis@dynaxo.pl or by traditional mail to the following address: **Dynaxo Sp. z o.o., Popowo 2a, 64-510 Wronki, POLAND**, as well as by the following:
 - a) inclusion of the personal data of the individual filing the complaint (telephone number, e-mail, responsible individual);
 - b) inclusion of the location of the Product's installation;
 - c) inclusion of the serial number of the cooktop;
 - d) inclusion of a legible copy of the proof of the initial purchase of the Product;
 - e) inclusion of a legible copy of the Connection Certificate of the cooktop and information confirming that the cooktop was installed in accordance with the Manual;
 - f) inclusion of a description of the identified damage/defect of the Product.
15. The Warranty does not cover the following:
 - a) a Product initially sold and used in a country outside of the **Region** covered by this Warranty;
 - b) a Product submitted in scope of a warranty claim with damaged or destroyed serial number or damaged or destroyed warranty seal;
 - c) a Product with an incomplete or incorrectly filled out Connection Certificate (Attachment no. 1 to the Terms of Warranty);
 - d) a Product damaged or defective due to:
 - use of the Product in a way other than that dictated by its regular purpose, specifically when the Product has been used in violation of the Installation and Operation Manual (Attachment no. 2 to the Terms of Warranty) attached to the Product, or due to other inappropriate use or negligence of the Product;
 - improper installation of the Product in violation of the Installation and Operation Manual (Attachment no. 2 to the Terms of Warranty), specifically connection of the Product to a gas supply by an individual without appropriate certification;
 - supply of inappropriate gas to the Product or connection of the Product to a different type of gas and pressure than the one configured by the manufacturer;
 - voided Warranty;
 - unauthorised servicing, repairs, or structural modification of the product performed by anyone other than the Guarantor or the Guarantor's Authorised Service Point;
 - use of a power supply unit other than the one specified on the Product rating plate.
 - e) damage created during regular use of the Product, including scratches and discolorations of the Product's glass and metal surfaces;
 - f) damage resulting from external factors beyond the control of the Guarantor.
16. The Guarantor is in no way responsible for damage resulting from or in association with improper use or operation of the Product unless such responsibility is dictated by commonly effective provisions of the law.
17. The Guarantor is in no way responsible for improper use or installation of the Product in violation of the Installation and Operation Manual.
18. If the Guarantor should establish a defect in the Product resulting from improper use or installation of the Product by the Customer in violation of the Installation and Operation Manual (Attachment no. 2 to the Terms of Warranty), the Guarantor is authorised to refuse repairs to said product free of charge and undertakes to present a justification for said decision in writing. In such an instance, the repairs may be subject to charges following arrangement of the costs with the Customer and approval of said costs by the Customer.
19. If the **Guarantor's service point should establish that a filed complaint is groundless as there is no flaw present or the** alleged (reported) damage to the Product **is not possible**, the service point shall reject the complaint on behalf of the Guarantor and present justification of said decision in writing. **In such an instance, the costs of groundless servicing shall be charged to the Customer in accordance with the information received by the Customer from the Guarantor's service point or in accordance with the prices enforced by the Guarantor's service point on the date of submission of the complaint in question.**
20. Adjustments to the Product in order to convert it to a different type of gas and pressure than the one configured by the manufacturer are not recognised as warranty repairs. Such services are paid and performed by the Guarantor or the Authorised Service Point following arrangement of the costs with the Customer and approval of said costs by the Customer.
21. Following expiration of the Warranty, the Guarantor may perform paid repairs, which shall be subject to arrangement of the scope and costs of said repairs with the Customer.
22. Matters not regulated by these Terms of Warranty are subject to general provisions. The Warranty does not exclude, restrict, or suspend the Customer's rights pursuant to implied statutory warranty.

Attachment no. 1 – Connection Certificate

Attachment no. 2 – DynaCook ceramic gas cooktop Installation and Operation Manual

Installation and Operation Manual
Gas Ceramic Cooktop
DynaCook X2 mini
DynaCook X2 DOMINO
Camping & Yacht

CONTENTS

CONNECTION CERTIFICATE	2
WARRANTY, SERVICING	3
WARRANTY CARD	3
SAFETY GUIDELINES	7
SAFE USE	8
ENVIRONMENT PROTECTION	11
SAVING ENERGY	11
UNPACKING.....	11
REMOVING USED APPLIANCES.....	11
DYNACOOK OPERATION MANUAL	12
GETTING TO KNOW YOUR DYNACOOK	12
PURPOSE	12
DESIGN.....	12
DYNACook X2 C&Y MINI	13
DYNACook X2 C&Y DOMINO	14
USING THE COOKTOP	15
Before first use	15
Turning on and setting heating zones	15
POWER function (DynaBooster)	17
STOP & GO.....	17
AUTO STOP	17
TIMER	17
TIMER CookOFF	17
TIMER CUSTOM	18
Automatic heating function	18
FHZ (Flexible Heating Zone) System.....	18
Child protection/Control panel lock.....	19
Gas leak protection	19
Residual heat indicator.....	19
Automatic operating time restriction.....	20
Cookware	21
CLEANING AND MAINTENANCE	21
Optimal and recommended cooktop cleaning instruments.....	22
Cleaning the Ceramic Cooktop Surface.....	23
Maintenance of the ceramic cooktop surface.....	25
Cleaning the hot air vent.....	25
TROUBLESHOOTING. WHAT TO DO WHEN.....	31
INSTALLATION MANUAL	33
ROOM	33
INSTALLING THE CERAMIC COOKTOP	34
Important guidelines.....	34
Cooktop ventilation.....	34
Cutting out the kitchen counter and installing the cooktop in the cutout	36
GAS SYSTEM	37
Guidelines for the gas installation technician	37
Liquid gas (e.g. propane-butane)	38
ELECTRICAL POWER SUPPLY.....	39
CONTROLLING AND MONITORING THE GAS, ELECTRICAL POWER, AND VENTILATION SYSTEMS	40
CONVERTING THE COOKTOP TO A DIFFERENT TYPE OF GAS	40
TECHNICAL DATA.....	41

Congratulations on your purchase of the STATE-OF-THE-ART DynaCook ceramic gas cooktop. You are now the proud owner of an ecological and innovative appliance, which ensures cooking convenience, low exploitation costs, and top safety standards. Please accept our wishes of unforgettable culinary experiences – thank you for the trust placed in our company. The DYNAXO team.



Do not activate the DynaCook until you read and understand this manual. The cooktop should be installed in accordance with effective provisions and used only in well-ventilated rooms.

SAFETY GUIDELINES

DEAR SIR OR MADAM,

The DynaCook is easy to use, extremely precise, and cooks with efficiency. Please read this Installation and Operation Manual carefully before using the appliance for the first time. After you read it, you will have no problems using the cooktop. By obeying the instructions of the Manual, you will make sure that you are using the appliance as intended. Please keep this manual always at hand for future reference. If you should hand the appliance over to a different user, make sure to include this documentation.

If you obey the Manual, you will have no problems using the cooktop.

Before your the DynaCook was packaged and shipped out to you, its safety and functions were subject to extensive testing by DYNAXO's quality control.

After unboxing, please check the condition of the device. Do not install it if it is damaged.

The cooktop is designed for cooking in individual households, on boats, in campers, and in camping trailers only. All other use (e.g. for purposes of indoor heating) is inconsistent with its purpose and may be dangerous.



The cooktop can be connected to an LPG (e.g. propane/butane) tank or an existing gas network only by a certified installation technician in compliance with all safety standards. Before installation, please make sure that the supplied gas and its pressure match the settings of the cooktop. You can find the configuration standards of the cooktop on its rating plate. The cooktop is not connected to exhaust discharge lines. It should be installed and connected in accordance with effective installation provisions. Please pay particular attention to appropriate ventilation.



THE USE OF A GAS COOKTOP RESULTS IN THE PRODUCTION OF HEAT, MOISTURE AND PRODUCTS OF COMBUSTION IN THE ROOM IN WHICH IT IS INSTALLED. **ENSURE THAT THE KITCHEN IS WELL VENTILATED ESPECIALLY WHEN THE COOKTOP IS IN USE.** PROLONGED INTENSIVE USE OF THE GAS COOKTOP MAY REQUIRE ADDITIONAL VENTILATION, FOR EXAMPLE THE INCREASING OF MECHANICAL VENTILATION WHERE PRESENT, ADDITIONAL VENTILATION TO SAFELY REMOVE THE PRODUCTS OF COMBUSTION TO OUTSIDE (EXTERNAL) AIR WHILST ALSO PROVIDING ROOM AIR CHANGES WITH ADDITIONAL VENTILATION. CONSULT A PROFESSIONAL BEFORE INSTALLATION OF THE ADDITIONAL VENTILATION.

Declaration of the manufacturer

The manufacturer hereby declares that this product fulfils the requirements of the European directives and regulations listed below:

- low voltage directive, 2014/35/EU,
- electromagnetic compatibility directive, 2014/30/EU,
- "gas appliances" directive, Regulation (EU) 2016/426

and, as such, is designated with the CE marking and holds the **declaration of conformity**.



If you have any concerns or have trouble understanding something in this manual – call our Service Centre for assistance.

tel. +48 606 649 549

e-mail: serwis@dynaxo.pl

www.dynacook.pl

<https://www.dynacook.pl/en/support/>

SAFE USE

- Always obey the standards and provisions of this Manual. Never let anyone who is not acquainted with the content of the Manual use the ceramic cooktop. This way, you are ensuring your safety and preventing the cooktop from being damaged.
- Never leave an operating cooktop unattended.
- Never let children play with the ceramic cooktop. Direct contact with an active ceramic cooktop produces the risk of getting burned!
- The ceramic cooktop **is not intended** for use by individuals (including children) with impaired physical, sensory, or mental capacity or individuals not acquainted with or instructed in scope of the appliance unless they are supervised by an individual responsible for their safety and in accordance with the Operation Manual of the ceramic cooktop.
- This appliance can be used by children aged 8 and up, individuals with impaired physical, sensory, or mental capacity, and individuals not acquainted with or not instructed in scope of the appliance as long as they are appropriately supervised or instructed in scope of using the appliance in a safe manner and understand the potential hazards. The appliance is not a toy for children. Children should not clean or perform maintenance of the appliance without supervision.
- **Never turn on a heating zone of the ceramic cooktop when there is no cookware with food standing on top of it.**
- Never cover/obstruct the hot exhaust vent with pots, foil, rags, or other objects.
The cooking process will produce hot steam, which will be released from the exhaust vent. Do not touch it (at the risk of being burned).
- If any **children** and/or **household pets** (e.g. cats) are present inside the room where the ceramic cooktop is installed, it is recommended to **activate the Control Panel Lock (child safety)** in order to avoid having appliance being turned on by accident by a child and/or pet.
- Fire hazard! Never put flammable objects on the cooktop.
- Fire hazard! Never keep flammable objects or sprays inside the drawers underneath the cooktop.
- Do not keep any objects on the cooktop.
- Never use the cooktop as a chopping block or working table unless it is protected with a cover designed and authorised by its manufacturer.
- Never hang any objects not resistant to high temperatures above the ceramic cooktop; this includes rags, mitts, foil, synthetic objects, sponges, etc.
- Never use the cooktop to cook food on aluminium foil, in aluminium cookware, or in synthetic cookware.
- Never place hot pots or pans on surfaces not resistant to high temperatures. Such conduct produces a risk of a fire or damage to said objects.
- If the cooktop needs to be equipped with a cover to hide or protect its surface, please use only those covers designed and authorised by its manufacturer. Use of inappropriate covers is prohibited and may lead to accidents.

INSTALLATION

- The cooktop can be **used** only after it is **installed in accordance with the Installation Manual**. If the cooktop is installed in violation of the Installation Manual, it is at risk of malfunctioning, which includes inadequate gas combustion leading to release of combustion products presenting a danger to human life and health (including carbon monoxide), low cooking efficiency, and damage.
- After installation of the ceramic cooktop, its power cable plug or power switch should be easy to access.
- The furniture encasing the cooktop must be resistant to temperatures of minimum 100°C. This applies to veneer, edges, synthetic surfaces, adhesives, and varnish.
- **Installing the cooktop in proximity of refrigeration appliances is not recommended.**
- Please make sure that the power cables of the cooktop or other devices never come into contact with the hot parts of the ceramic cooktop.
- Please make sure to keep small kitchen appliances and their power cables away from the cooktop so they never touch a hot zone directly as they are not resistant to high temperatures.
- **Cooktops installed on boats should be equipped with pot holders** to prevent pots from sliding on the surface of the cooktop while cooking when the boat is in motion. Cooktops installed on boats are factory-fitted with pot holders. Pot holders are available from the cooktop manufacturer as a separate accessory.

VENTILATION

- A working cooktop consumes oxygen and emits combustion products such as heat, humidity, carbon dioxide, and carbon monoxide inside the room where it is installed. Please make sure that the room where the cooktop is used is well ventilated and that the ventilation pathways are open during cooking. Please keep the natural ventilation ports open as appropriate and install forms of mechanical ventilation, e.g. a hood with mechanical exhaust. **Do not close the room's ventilation pathways when using the cooktop.**

- A visible asphyxiation risk warning sign with minimum 4 mm letter height should be installed in a visible location in proximity/next to the cooktop.



DANGER: AVOID ASPHYXIATION. COOKTOP PRODUCES CARBON MONOXIDE. MAINTAIN OPEN VENTILATION WHEN COOKTOP IS IN USE. DO NOT USE FOR SPACE HEATING.

- When the cooktop is turned on for the first time, an unpleasant “new appliance” smell may arise. The smell will go away after a several hours of use. It is recommended to air out the kitchen space extensively during the initial hours of use.
- Unpleasant smell being emitted from the cooktop when in use may be the odour added to gas.
- Prolonged and intensive use of the appliance may require you to e.g. open the window or ensure more efficient ventilation, e.g. increase mechanical ventilation efficiency.
- If are unable to turn on the burner/heating zone for over 60 seconds, please disconnect the gas supply and air out the room.

GAS SYSTEM

- **IF YOU SHOULD SUSPECT A GAS LEAK, DO NOT:** light matches, lighters, or cigarettes, turn electrical appliances (e.g. a bell or light) on or off, or use other electrical and mechanical appliances producing an electrical or electrostatic discharge spark. In such instances, you must immediately close the valve of the system supplying gas to the appliance, air out the room, and call for assistance of an individual authorised to remove the defect.
- **Never connect** any antenna cables, e.g. radios, to the gas supply system.
- In the event of ignition of the gas leaking from the system supplying gas to the appliance, you must immediately close the valve in your gas supply system.
- In the event of ignition of gas leaking from a gas tank valve, cover the tank with a wet blanket in order to cool it off and then close the valve of the tank. When cooled down, take the tank outside. Never use a damaged tank.
- In the event of prolonged downtime in use of a ceramic cooktop connected to a gas tank, please close the valve of the tank.
- **Do not use** solutions containing ammonia to check for gas leaks.

COOKTOP HOT SURFACE INDICATOR, HOT HEATING ZONES

- Danger of being burned! Never touch the heating zones or metal elements of the cooktop. Keep small children away from the cooktop surface.
- The cooktop is equipped with status indicators. The indicators can be found on the control panel. For more information about indicator messages, please read the chapter entitled **Using the Cooktop**.
- The heating zone (residual heat) indicator embedded in the control system of the ceramic cooktop indicates when the heating zones are turned on or still hot. The heating zone (residual heat) indicator will remain on while the heating zones are hot.
- **In the event of a power outage during use of the cooktop, all heating zone settings and heating zone indicators are reset.** When the power supply returns, it is recommended to take particular care as the used heating zones are hot and touching them puts you at risk of being burned!



The ceramic surface of the cooktop may be hot even when no information is displayed on the control panel!

- Never leave the ceramic cooktop unattended during frying. Overheating or boiling oil and fats may be spontaneously ignited.
- The heating zone and the cookware bottom must both be dry. If the space between the heating zone and the pot bottom is wet, steam pressure may be produced. This pressure may make the pot “jump” unexpectedly and expose the user to the danger of e.g. being burned.
- Do not place synthetic or aluminium cookware or utensils, e.g. spoons, forks, aluminium foil, etc. on a hot cooktop.
- Do not use the surface of the ceramic cooktop for storage purposes.
- Do not place empty cookware on active heating zones as this may lead to damage.
- The heating zone power is regulated by being cyclically turned on and off. Turning on the burner (igniting the gas) is initiated by the ignition spark (electric spark generator) and is accompanied by the characteristic sound of a jumping electric spark.

CLEANING, STAINS

- Always obey the guidelines for cleaning and maintenance of the ceramic cooktop in accordance with the chapter entitled **Cleaning and Maintenance**. The manufacturer is not held liable in any way for damage to the cooktop resulting from improper use, maintenance, or cleaning.

- Do not clean the ceramic cooktop with abrasive or corrosive cleaning agents, which can cause permanent scratches and damage to the appliance and damage the decorative imprint on the ceramic surface.
- Never place cookware with wet bottoms on hot heating zones as this may produce irreversible damage to the cooktop (permanent stains).
- Never let the cooktop be contaminated or covered with spillage. This applies to sugar in particular, which enters a reaction with the ceramic cooktop and may produce irreversible damage. All residue must be promptly removed.
- Never let sugar, citric acid, salt, etc. in solid or liquid state or synthetic materials come into contact with hot heating zones.
- If any sugar or synthetic material should accidentally come into contact with a hot cooktop, do not turn off the cooktop. Scrape the sugar or synthetic material off with a sharp scrubber dedicated to ceramic surfaces. Protect your hands from heat and cuts – please read the chapter entitled **Cleaning the Ceramic Cooktop Surface**.

CERAMIC GLASS DAMAGE, COOKWARE

- The heating surface of the ceramic cooktop is resistant to thermal shock and is not sensitive to hot or cold.
- Do not strike the surface of the ceramic cooktop or drop anything on it. When something, e.g. a spice bottle, hits the surface, it may cause the ceramic cooktop to crack or chip.
- Never use cookware with sharp edges, which could potentially damage the ceramic cooktop.
- Never place anything with total weight exceeding 25 kg on the ceramic cooktop.
- Use only cookware with flat and dry bottoms and no sharp or jagged edges or risk permanent scratches in the cooktop.
- If the cooktop surface should crack, you must immediately disconnect it from the source of electrical power supply and close the gas valve in the system supplying gas to the appliance. It is forbidden to use a cooktop with a cracked working surface.

TECHNICAL DEFECTS

- Never use a cooktop, which is not in technical operating order. **All damages to the cooktop can be removed by a service point authorised by the manufacturer only.**
- **Repairs of the cooktop performed by unauthorised individuals present a serious hazard to the user of the appliance!**
- In all situations resulting from technical malfunctions, you must immediately turn off the electrical power supply and the valve of your gas supply system and report the malfunction to the appropriate service point.
- Unauthorised modifications to the ceramic cooktop are strictly prohibited.
- Unauthorised conversion of the ceramic cooktop to a different type of gas or modification of the internal gas system of the cooktop is strictly prohibited. Such conversions or modifications can be performed only by service points authorised by the manufacturer.
- **If your cooktop is malfunctioning**, please read the chapter entitled **Troubleshooting. What to do when...** before calling for service assistance.



If you have any concerns or have trouble understanding something in this manual – call our Service Centre for assistance.

tel. +48 606 649 549

e-mail: serwis@dynaxo.pl

www.dynacook.pl

<https://www.dynacook.pl/en/support/>



The manufacturer cannot be held liable in any way for use of the ceramic cooktop not in accordance with the Operation Manual and its installation not in accordance with the Installation Manual.

ENVIRONMENT PROTECTION



SAVING ENERGY

If you consume energy responsibly, you not only help out your household budget, but you are also consciously benefiting the natural environment. Let's all do our part and conserve energy! We can do so by:

- Using appropriate cookware. Cookware with flat and heavy bottoms will save up to 1/3 of energy. **Remember to close the lid.** If you don't use one, your energy consumption will multiply!
- Make sure that the heating zones and cookware bottoms are clean. Residue disrupts heat transfer – burnt on contamination can be removed only with cleaning agents, which have a major impact on the natural environment.
- Try to refrain from "peeking in pans" when there is no need to do so.
- Do not install the cooktop in direct proximity of refrigerators/freezers. If you do so, the energy consumption of your refrigerating appliances will needlessly grow.
- Use small cookware for small amounts of food. A big pot with little content consumes plenty of energy.
- Vegetables are cooked best briefly and in little water. This way, you save both energy and water and your vegetables retain their vitamins and minerals.
- Lower the heat setting of the appliance at the right times.
- Take maximum advantage of the residual heat produced by the cooktop. In the event of lengthy cooking, you can turn off the heating zone 5-10 minutes before the end of the cooking process.



UNPACKING

The appliance is secured from damage for the time of transport. After unpacking the appliance, please remove the packaging elements in a way, which will not produce a hazard to the environmental.

All materials used for packaging purposes are friendly to the environment and 100% recyclable.



Keep children away from the packaging materials (polyethylene bags, Styrofoam fragments, etc.) during the unpacking process.

REMOVING USED APPLIANCES

This device is marked with the crossed-out waste bin symbol in accordance with European Directive **2012/19/EU** and the law on waste electric and electronic equipment.



This symbol means that the appliance cannot be discarded together with other household waste after the end of its lifespan. The user must deliver it to an electric and electronic equipment waste collector, including to local collection points, stores, and regional units, which compose an appropriate system collecting such equipment.

Through proper handling of used electric and electronic equipment, you are helping eliminate the consequences of the presence of dangerous substances harmful to human life and health as well as improper storage and processing of such equipment.

DynaCook OPERATION MANUAL

GETTING TO KNOW YOUR DynaCook

Purpose

The DynaCook ceramic gas cooktop is the newest generation of gas-based heating appliances. It offers the “gas under glass” technology and is adapted for installation in a kitchen counter.

The cooktop is designed for use in households, on boats, in campers, and in camping trailers only for purposes of cooking, frying, and heating food.

The innovative solutions patented by DYNAXO and applied in the DynaCook ensure convenient use and low exploitations costs with fulfilment of top safety standards.

Design

The DynaCook ceramic gas cooktop is equipped with innovative and patented gas burners equipped individually with a flame ignition and gas combustion control system. In order to ensure full cooking convenience and safety, the gas burners are controlled from the electronic touch control system integrated in the cooktop.

The burners are located underneath a ceramic surface with graphic designations of the heating zones directly above the burners. The cooktop is operated from touch control panel in a safe area designated on the ceramic surface. Changes to the burner power settings are shown on the displays. The electrical power system of the DynaCook ceramic cooktop is safe (12 V DC). Inadequate voltage is strictly prohibited as it may cause damage to the cooktop or make it malfunction.

DynaCook X2 C&Y mini

General view of the DynaCook X2 C&Y mini

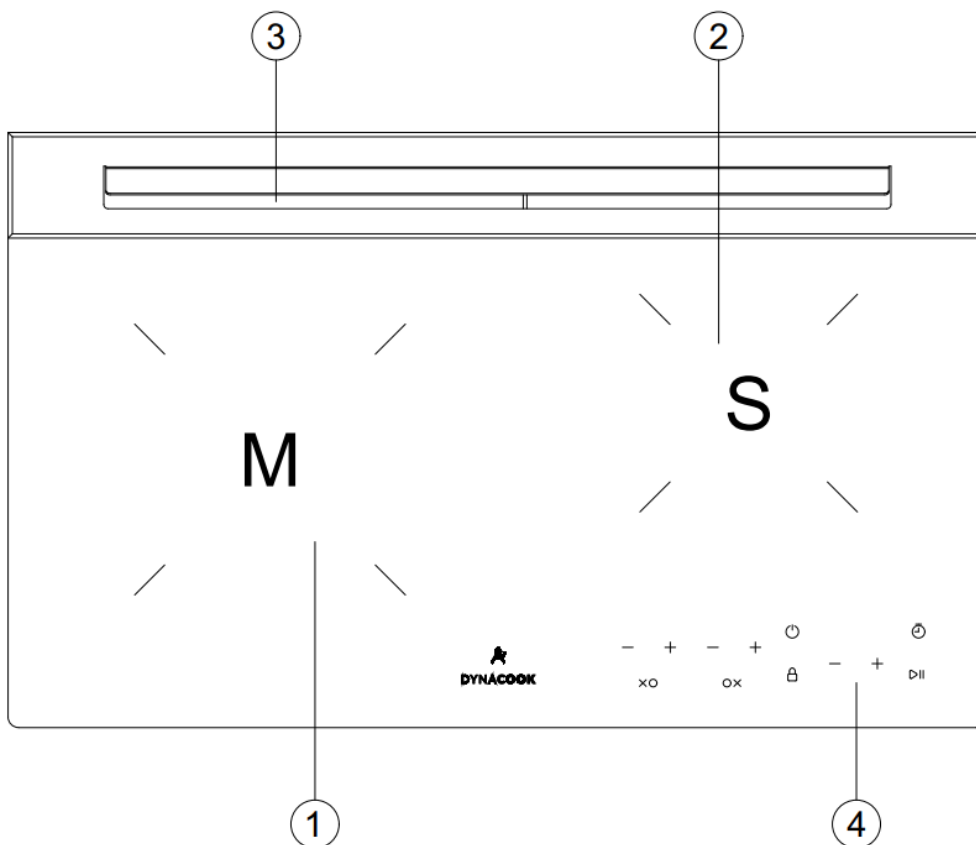

1. Medium burner M
2. Small burner S
3. Hot exhaust
4. Control panel

View of the DynaCook X2 C&Y mini control panel

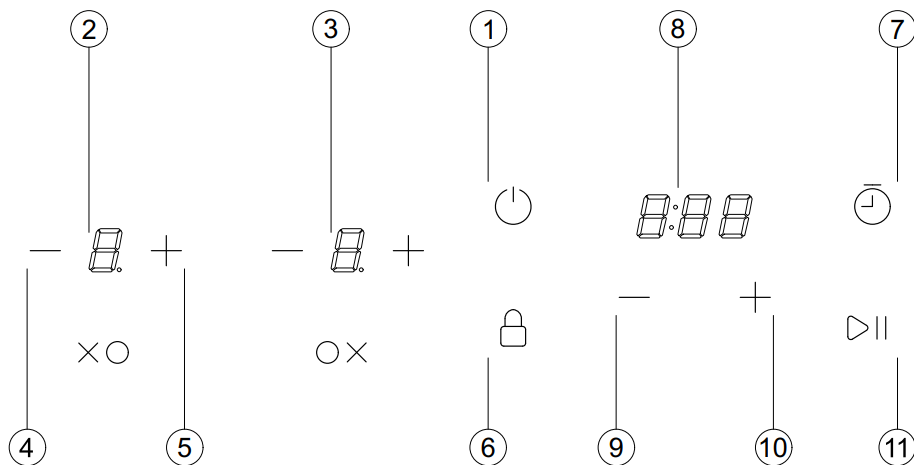

1. ON/OFF switch
2. M burner power display
3. S burner power display
4. Burner power down
5. Burner power up
6. Control panel lock

7. TIMER
8. Clock display
9. Decreasing clock time
10. Increasing clock time
11. STOP & GO

DynaCook X2 C&Y DOMINO

General view of the DynaCook X2 C&Y DOMINO

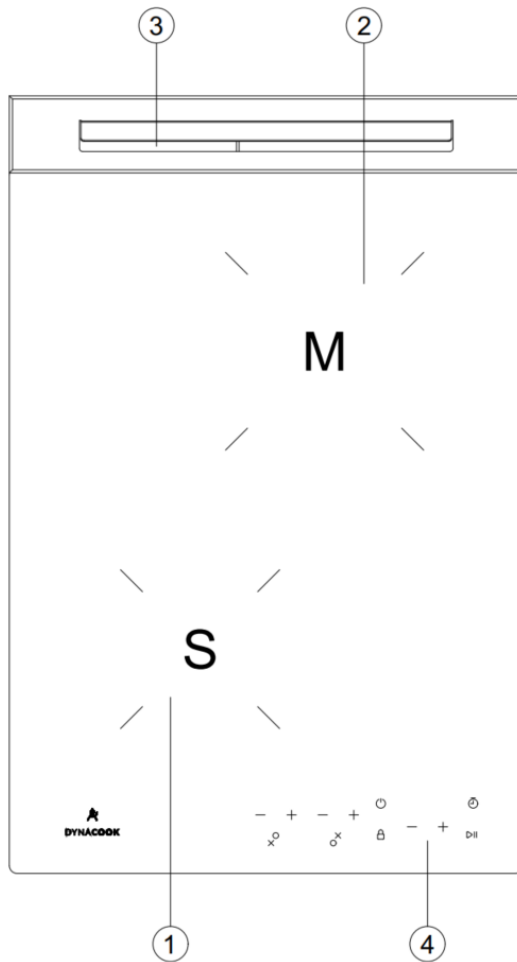

1. Small burner S
2. Medium burner M
3. Hot exhaust
4. Control panel

View of the DynaCook X2 C&Y DOMINO control panel

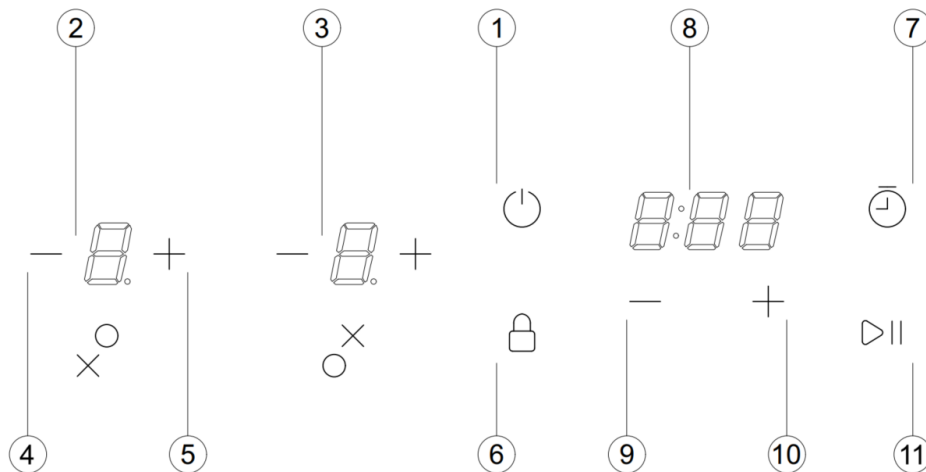

1. ON/OFF switch
2. S burner power display
3. M burner power display
4. Burner power down
5. Burner power up
6. Control panel lock

7. TIMER
8. Clock display
9. Decreasing clock time
10. Increasing clock time
11. STOP & GO

Using the Cooktop

Before first use

- First of all, please carefully clean the ceramic cooktop. Treat the ceramic surface as you would treat a glass surface.
- Perform all maintenance tasks with preservation of safety precautions and the standards specified in this manual.
- When you activate the cooktop for the first time after a change of gas tanks, a gas outage in the supply system, or following prolonged downtime, it may take longer to turn on due to the presence of air in the gas system. In such instances, the activated heating zone may produce a momentary louder sound ("snort"), which is normal and completely safe.



Never turn on a heating zone when there is no cookware with food standing on top of it.

Turning on and setting heating zones



Guidelines:

- After being turned on with ON/OFF switch, the heating zone control sensors of the cooktop are active (in standby mode); if no control sensor is touched within 10 seconds, the cooktop will turn itself off automatically.
- The pulsating operation of heating zones means in practice that when the heating zone is not combusting gas (several seconds in a single cycle), it releases heat to the used cookware – this way, it saves gas consumption.



If a burner (heating zone) fails to ignite, the setting display of the appropriate heating zone (burner) will display the message "G" (see: *Gas leak protection*). In such instances, please wait at least 60 seconds before attempting to turn on the heating zone (burner) again.

Power setting indicator	Heat setting
1	lowest
9	highest
P	POWER function

- Each [+] or [-] sensor is assigned to an appropriate heating zone and is used to set the heating zone power .



All heat settings between 1 and 9 have their own intermediate settings, which are marked with the appropriate digit and a dot (e.g. 4.)

TURNING ON A HEATING ZONE/HEATING ZONES

- a) *place the cookware with food on the appropriate heating zone*
 b) *touch the sensor of ON/OFF switch with your finger* (the digits 0 will appear on the heating zone power displays)



- touch sensor [+] with your finger within **10 seconds**: turns on the **POWER** function, which is indicated with "P"

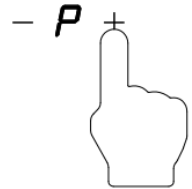

- touch sensor [-] with your finger within **10 seconds**: this will set the heating zone to level "4"

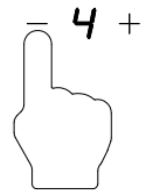

c) *when you touch the following heating zone setting sensor:*

[+] - you will increase the power

[-] - you will reduce the power

AUTOMATIC HEATING ZONE SETTING:

- if you touch sensor [+] for longer than 1 s, the heating power will automatically and seamlessly increase until the **POWER "P"** function is turned on
- if you touch sensor [-] for longer than 1 s, the heating zone setting will automatically reduce to "0"

The **heating zone power** (power setting between 1 and 9) is adjusted when the heating zone is **cyclically turned on and off**. This table presents the burner operation cycle according to the set power level.

Power setting	Burner operation time [s]	Burner inactivity time [s]
1	6	54
1.	9	51
2	12	48
2.	15	45
3	18	42
3.	21	39
4	24	36
4.	27	33
5	30	30
5.	33	27
6	36	24
6.	39	21
7	42	18
7.	45	15
8	48	12
8.	51	9
9	54	6
P	1800	0

TURNING OFF A HEATING ZONE/HEATING ZONES:

- Touch both the [+] and [-] sensors of the given heating zone simultaneously irrespectively of the set heat level



- Keep touching the [+] or [-] sensor until the digit "0" appears on the display
- Touch the **ON/OFF** sensor when a heating zone/heating zones are on to turn off all heating zones.

After the heating zone/heating zones is/are turned off, the burner indicator may display the letter "H" or "h" to indicate a hot heating zone (see: Residual heat indicator).

POWER function (DynaBooster)

The POWER (DynaBooster) function increases the heating zone power and maintains it for a specific time so we can make our food much faster. All DynaCook burners are equipped with this function. Indicated on the burner power display with the letter "P"



How do you quickly set a heating zone to "P"? – see: [Turning on heating zones](#) and [Seamless heating zone adjustment](#).



Indicators: After 30 minutes, the POWER function turns off, the "P" symbol disappears, and the heating zone goes into cyclical mode with heating power set to "9".

STOP & GO

The STOP & GO function immediately turns off all heating zones. When pressed again, it restores all previous settings.

Just press  and all heating zones will go into "all fields off" mode so nothing boils over or burns. When you want to resume cooking, just press  once again!

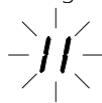

The function is indicated with a flashing icon

AUTO STOP

Keep yourself and everyone else at home safe. The AUTO STOP function turns off the cooktop automatically in the event of a spill to eliminate the risk of damage to the cooktop and furniture.

TIMER

Control your cooking. The TIMER function presets accurate cooking time to ensure that even the most demanding dishes come out perfect.

Turning on:

1. Touch sensor  - 0:00 will appear on the clock display.
 2. Use the clock sensors + and - to set the alarm countdown. When the time is set, the TIMER turns on automatically and counts the time down to zero, which is indicated by the flashing colon on the clock display.
- The TIMER countdown can be changed at any time with clock sensors + and -. When the countdown is done, a sound is heard (which repeats every minute) and the 0:00 display starts to flash.



The TIMER can be **turned off** at any time by touching sensor 

TIMER CookOFF

Automate your cooking process and stop worrying about things you don't have to! The TIMER CookOFF function sets the entire cooktop to turn off automatically after the preset time.

Turning on TIMER CookOFF:

1. Hold sensor  for minimum 3 seconds – the letter A will start to flash on the power setting displays and 0:00 will start to flash on the clock display
2. Use clock sensors + and - to set the time for the cooktop to turn off
3. Set the power of the burners you want to use for cooking within 10 seconds

When TIMER CookOFF mode is active, the active burner power displays show an animation (moving lines) and the clock display counts down the time for the cooktop to turn off. The cooktop operating time can be changed at any time with clock sensors + and - and the power settings of each burner. When the countdown is done, the cooktop turns off, a sound is heard (which repeats every minute), and the 0:00 display starts to flash.



TIMER CookOFF can be **turned off** at any time by holding sensor  for minimum 3 seconds.

TIMER CUSTOM

Set every burner to cook individually. The **TIMER Custom** function turns off each burner after the preset time.

Turning on:

1. Hold sensor  for minimum 3 seconds - the letter A will start to flash on the power setting displays and 0:00 will start to flash on the clock display.
2. Set the power of the burner you want to use.
3. Use clock sensors + and – to set the time for the burner to turn off. After setting the time, the power display shows an animation (moving lines) and the clock display counts down the time until the burner turns off.

If you want to turn on another burner in **TIMER CUSTOM** mode:

1. Set burner power
2. Touch sensor  to make the power display of the burner in question flash together with the 0:00 clock display
3. Use clock sensors + and – to set the time for the burner to turn off. After setting the time, the power display shows an animation (moving lines) and the clock display counts down the time for the burner to turn off.



The displayed time applies to the burner with power display showing the animation (moving lines).

Viewing set burner times/changing burner times:

Touch button  - the time appears and the power display of the burner set in **TIMER CUSTOM** mode starts to flash.

Touch button  again to display subsequent burners set in **TIMER CUSTOM** mode and their countdown.

When you are switching burners set in **TIMER CUSTOM** mode, you can change set burner countdown with clock sensors + and –.

The burner power settings can be changed at any time during burner operation in **TIMER CUSTOM** mode.

When the set time for the given burner expires, the burner turns off automatically and a sound is heard.

When **TIMER CUSTOM** mode expires on all burners operating in this mode, the **TIMER CUSTOM** function turns off.



TIMER CUSTOM can be **turned off** at any time by holding sensor  for minimum 3 seconds.



Burners turned on and not set to **TIMER CUSTOM** mode where the clock displays 0:00 when viewing set times must be turned off manually.

Automatic heating function

This function is activated without the user's prompt when a given cold heating zone is activated (the function is not triggered when the zone is hot). The automatic heating function turns off automatically and is used to bring the heating zone to the desired temperature faster.

FHZ (Flexible Heating Zone) System

The innovative design of the DynaCook ceramic gas cooktop includes the Flexible Heating Zone (FHZ) System. A flexible heating zone allows you to use the given heating zone for cookware with diameters according to those presented in the table.

Heating zone range (diameter) (FHZ)		Burner name (cooktop design)
Permissible pot diameters		
From	To	
130 mm	200 mm	Medium burner
105 mm	150 mm	Small burner

Child protection/Control panel lock

In order to prevent accidental activation of the ceramic cooktop (e.g. by a child or household pet, e.g. cat), please use the control panel lock function.

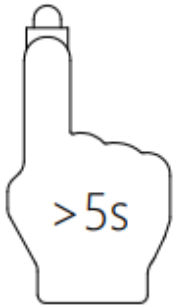

Turning on the lock:

- touch the lock sensor for at least 5 s.

The control panel lock will be activated when you see the lock symbol "L" appear and hear the sound signal.



Turning off the lock:

- touch the lock sensor for at least 5 s.

The control panel lock will be deactivated when you see the lock symbol disappear and hear the sound signal.



When the control panel is locked, the heating zones cannot be turned on. When the lock is activated, you will see the lock symbol "L" appear and hear a sound signal.

Gas leak protection

- The DynaCook ceramic cooktop is equipped with numerous safeguards to guarantee its safe use. One of them is the gas leak safeguard. This solution has been subject to numerous safety tests based on continuous control of the gas combustion process. In the event of any problems with gas combustion, e.g. no ignition, the gas leak safeguard automatically cuts off gas supply to the burner. The letter "G" appears on the display of the heating zone in question and a short intermittent sound signal is heard. This causes the cooktop to lock automatically. The lock can be deactivated as discussed in the chapter entitled **Troubleshooting. What to do when...**

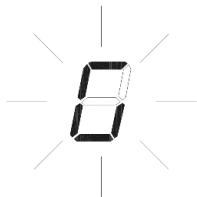

Guideline: The "G" code may appear when no gas is being supplied from e.g. the gas tank or gas network.

Residual heat indicator

The ceramic cooktop is equipped with a **two-level** residual heat indicator for every heating zone.

If you see "H" on the display, it means that *"the heating zone is hot"*. You can use this zone e.g. to keep your food warm.



If you see "h" on the display, it means that *"the heating zone is warm"*. The "h" disappears when the heating zone cools down appropriately.





In the areas of the heating zones, hot steam discharge zones, and hot steam vents, the cooktop surface is very hot both during the cooking process and for a certain time afterwards even when the heating zones are off. Due to the above, when you see "H" or "h" on the heating zone display, please take special caution, do not touch the heating zones, hot steam discharge zones, and hot steam vents at the risk of being burned, and do not place any objects not resistant to high temperatures, including synthetic objects, on top of them.



When the power supply is cut off, the residual heat indicator is turned off. In the event of a power outage, please take special caution to avoid being burned.



When the heating zones are on, the hot steam discharge zones, and the hot steam vents are very hot. Do not touch them at the risk of being burned! Never place any objects, which are not resistant to high temperatures, on top of them, including synthetic objects. When cooking, make sure that nothing boils over and limit grease "spraying" onto the hot steam discharge zones, and the hot steam vents, as residue food and grease may be burnt on.

Burnt on remains are best removed with a scraper dedicated to ceramic surfaces -> please see the chapter entitled Cleaning and Maintenance.

Automatic operating time restriction

In order to ensure its safety, the cooktop is equipped with a **shut-down timer** for every heating zone. The maximum operating time is determined by the setting of the given heating zone.

If the power setting remains unchanged for some time (see table), the heating zone in question will turn off automatically. After the heating zone turns off automatically, you can reassume cooking at any time and use the individual heating zones in accordance with the instruction manual.

Heating zone setting	Maximum heating zone operation time (h)
1	10
1.	10
2	10
2.	5
3	5
3.	5
4	5
4.	4
5	4
5.	3
6	2.5
6.	2.5
7	2
7.	1.5
8	1.5
8.	1.5
9	1

Cookware

No special cookware is required (as opposed to induction cooktops).

Use only dedicated cookware and bakeware on the ceramic cooktop. Always obey the instructions of their manufacturers. **Do not use cookware extending beyond the edges of the cooktop.**



Never use cookware with "raw" aluminium or copper bottoms.

Cookware with aluminium or copper bottoms may produce permanent metallic discolorations on the ceramic surface, which are very hard to remove. Please take particular care when using enamel cookware. Spillage from such cookware may cause irreversible damage to the ceramic cooktop.

In order to **reduce the cooking time to maximum**, please ensure the following:

- **the cookware bottom must be flat and stable to ensure that the entire bottom surface** adheres to the heating zone of the ceramic cooktop (**bottoms with sharp or jagged edges and charred food remains may scratch the ceramic cooktop and produce an abrasive effect**),

- the cookware should have a tightly fitting lid,

- the diameter of the cookware's bottom should correspond to that presented in the table in the chapter entitled *FHZ System*.

Dirty heating zone and cookware surfaces will prevent you from taking full and economic advantage of the heat.

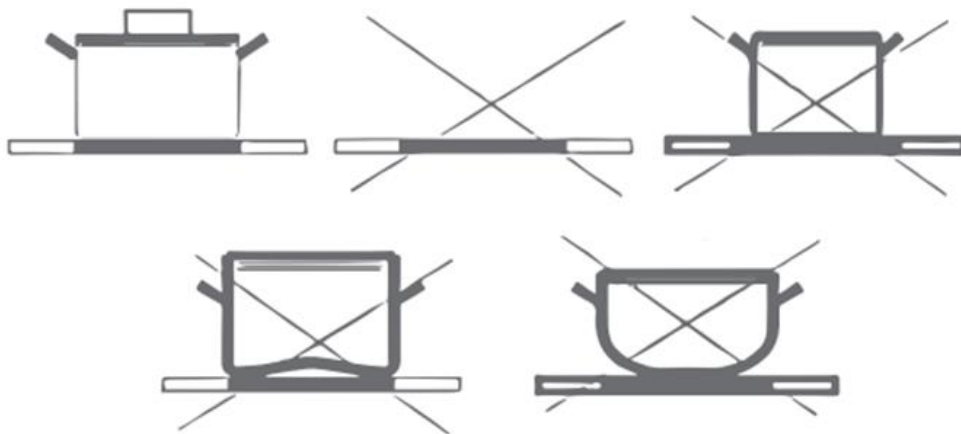

Cleaning and Maintenance

Regular cleaning is easy and requires little time.

The **best way to avoid stains on the ceramic cooktop is to regularly clean it after every cooking**. This way, the cooking residue will not stick as hard.



Do not clean the cooktop until it is cold.



If the cooktop surface is cracked, you must immediately close the gas supply and turn off the electrical power supply to avoid being shocked. In order to do so, please switch off the fuse or pull the plug out of the power socket. Next, you should report the malfunction to the service point.



Never use aggressive or corrosive agents (acids, sodium hydroxide or hypochlorite, etc.) to clean the appliance.



The manufacturer is in no way liable in scope of the warranty if cleaning and maintenance of the ceramic cooktop is mishandled.



Never clean the ceramic cooktop surface with abrasive instruments like sandpaper or the rough side of a dishwashing sponge.

The **cleaning agents and scrubbers** dedicated to ceramic surfaces are available from stores carrying household chemicals, drugstores, and stores carrying household appliances and accessories.

Never apply a cleaning agent onto a hot ceramic surface. Wipe the cleaning agent off with a wet cloth before reheating the ceramic surface or risk having the surface being damaged by the agent.

Optimal and recommended cooktop cleaning instruments

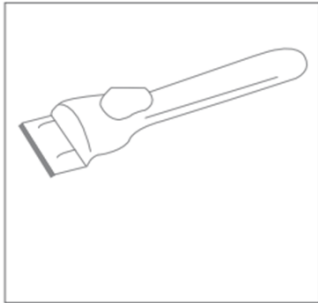

The scraper is used to remove burnt on layers and strong residue on the glass (ceramic surface).

The ceramic surface of the cooktop can be cleaned only with an extended scraper blade in accordance with its instruction manual. Otherwise, the Customer is at risk of suffering physical injury and the cooktop is exposed to having its surface scratched.



The scraper blade is very sharp. Please be careful, because you may cut yourself. When you are not using the scraper, make sure to secure the blade in accordance with the instructions of its manufacturer. A damaged blade must be promptly replaced.

Ceramic surface cleaning agent

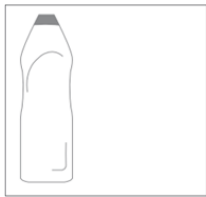

Ceramic surface maintenance agent

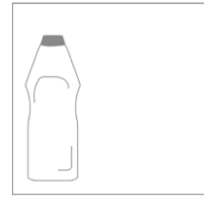

Cleaning the Ceramic Cooktop Surface



Do not clean the cooktop until it is cold.

Use only cleaning agents dedicated to ceramic glass surfaces and follow the guidelines of the manufacturer presented on the packaging of said agents.

Cleaning of a ceramic surface is subject to the same guidelines as cleaning of a glass surface. Never use the following:

- abrasive, aggressive, or corrosive cleaning agents,
- scrubbing powder, sandpaper,
- corrosion removal agents,
- high pressure or steam washers,
- dishwasher cleaning agents,
- oven cleaning agents.

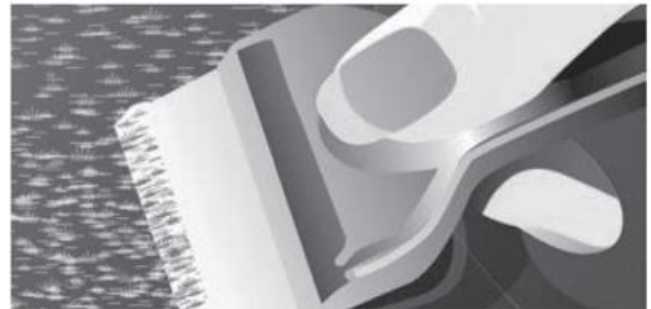

1. In order to clean the ceramic surface well, please first remove major residue and food stains with a scraper or sponge dedicated to ceramic surfaces.



2. Next, apply the right amount of the cleaning agent onto the ceramic surface and distribute it with an appropriate sponge/cloth/paper towel. Leave for 5 – 10 minutes.



3. Next, wipe off the surface with a wet cloth/sponge and wipe it dry. All clean!



Do not clean the cooktop until it is cold.

Contamination type	Cleaning method – ORDER OF STEPS
1. Light non-burnt residue, streaks	<ul style="list-style-type: none"> a) wipe off with a wet dish sponge with a little ceramic surface cleaning agent b) after cleaning - wipe the surface dry
2. Strong residue	<ul style="list-style-type: none"> a) use a ceramic surface scrubber to remove all burnt on and solid pieces b) collect the dirt removed by the ceramic surface scrubber with a wet sponge/cloth c) apply a ceramic surface cleaning agent onto the strong residue, distribute with a sponge, and wait for around 5-10 minutes, d) clean the surface with a wet sponge/cloth e) wipe surface off until clean, f) after cleaning - wipe the surface dry
3. Scale stains (e.g. from water boiling over)	<p>Method 1:</p> <ul style="list-style-type: none"> a) wipe off with a wet dish sponge with a little ceramic surface cleaning agent b) after cleaning - wipe the surface dry <p>Method 2:</p> <ul style="list-style-type: none"> a) wipe off with a wet sponge dipped in spirit vinegar (10% solution) b) pour some baking soda on the wet stain and wait 5 minutes c) wipe off with sponge d) after cleaning - wipe the surface dry
4. Bright pearl-tinted stains (aluminium residue)	<p>Shiny stains are scratches produced by cookware bottoms, especially if you use cookware with aluminium bottoms or inappropriate cleaning agents. These stains are hard to remove with cleaning agents available on the market.</p> <p>Method 1:</p> <ul style="list-style-type: none"> a) wet the stain with spirit vinegar (10 % solution) b) wait 10-15 min. c) apply a ceramic surface maintenance agent to the stain (do not remove the vinegar) -> wait until the agent dries and thickens d) wipe the aforementioned agents e) clean with a ceramic surface maintenance agent f) after cleaning - wipe the surface dry <p>Method 2:</p> <ul style="list-style-type: none"> a) prepare a bleach and water solution (proportions: 1 part bleach and 1 part water) b) dip a paper towel in the prepared solution c) place a wet, soaked towel on the stain and wait for minimum 1 hour d) wipe the surface dry e) clean with a ceramic surface maintenance agent f) after cleaning - wipe the surface dry <p>If needed, repeat all of the above.</p>
5. Sugar, residue food containing sugar, synthetic materials, aluminium foil, salt, citric acid Sugar and products containing sugar may cause permanent damage to the ceramic surface!	<p>Do not turn off the given heating zone!</p> <div style="border: 1px solid black; padding: 5px; display: flex; align-items: center;">  <p>Caution. Risk of being burned. Use only a scrubber suitable for ceramic surfaces.</p> </div> <ul style="list-style-type: none"> a) use a ceramic surface scrubber to immediately scrub off the remains (while still hot) from the hot heating zone b) when the dirt is removed, you can turn off the ceramic cooktop and clean the ceramic surface when it cools down according to the appropriate instance discussed above

Examples of damaged ceramic surfaces not covered by the warranty:

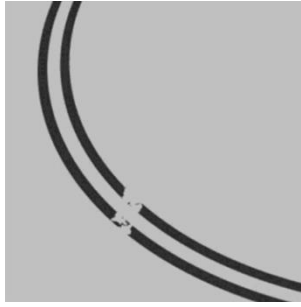

Surface decoration damaged due to application of an inappropriate cleaning agent.

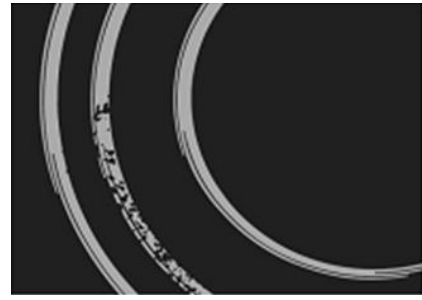

Permanent damage to the surface with sugar and products containing sugar.



Grains of sand, which may fall on the cooktop when you are peeling potatoes, rinsing lettuce, etc. may scratch the surface when you move the cookware. Please pay particular attention to keep grains of sand off the cooktop.



Never clean the ceramic cooktop surface with abrasive instruments like sandpaper or the rough side of a dishwashing sponge.

Discolorations and scratches on the ceramic surface have no effect on the operating order and stability of the cooktop. In most instances, they are the consequence of burnt food residue or cookware (specifically cookware with aluminium or copper bottoms) being moved on the surface. Such discolorations are rather difficult to remove. All of the aforementioned discolorations and scratches are purely aesthetical, result from the way the cooktop is used, and are not covered by the warranty.

Maintenance of the ceramic cooktop surface



Do not perform maintenance on the cooktop until it is cold.

The cooktop must be subject to maintenance and protection agents dedicated to ceramic glass, e.g. ceramic surface cleaning agents. Please follow the guidelines of the manufacturer presented on the packaging of said agents.

Cleaning the hot air vent



Do not clean the hot steam vent elements of the cooktop until they are cold.



When cleaning the hot steam vent elements, please take particular care due to the risk of cutting yourself with an edge of the material used to make said elements.



When cleaning hot steam vent elements made of materials other than glass, do not use the ceramic surface scraper.

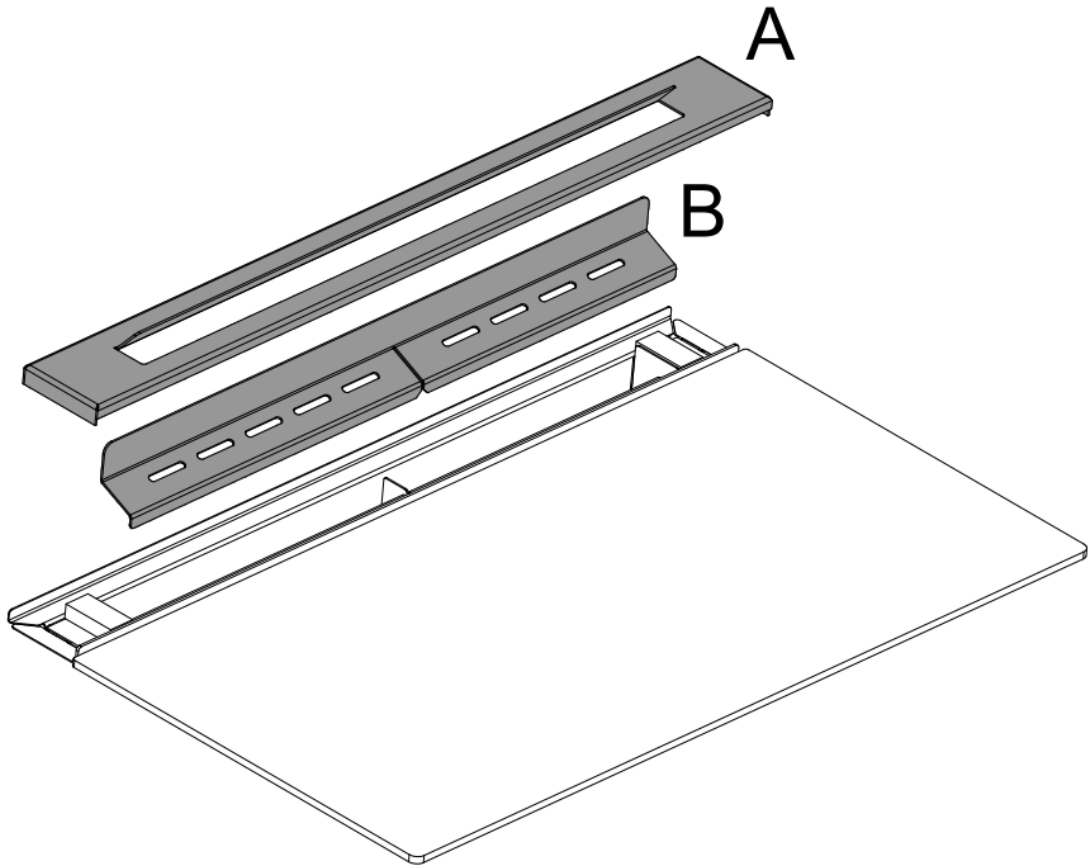

Outer exhaust vent element (A)

Inner exhaust vent element (B)

Removing exhaust vent elements

Removing the outer exhaust vent element (A)

Removing the inner exhaust vent element (B)

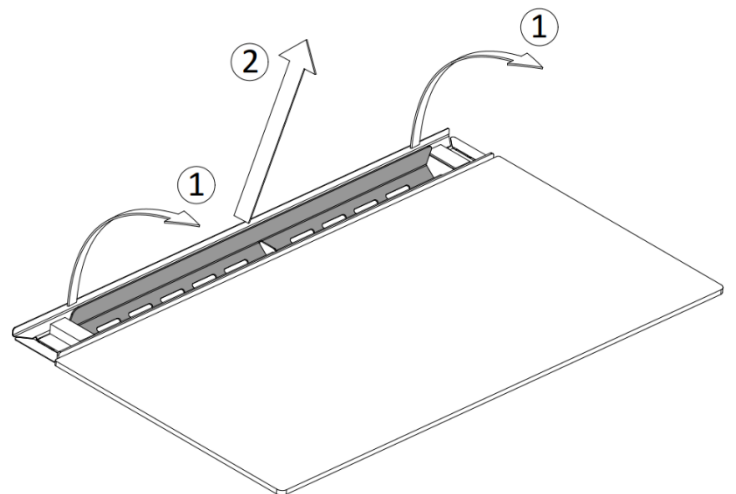
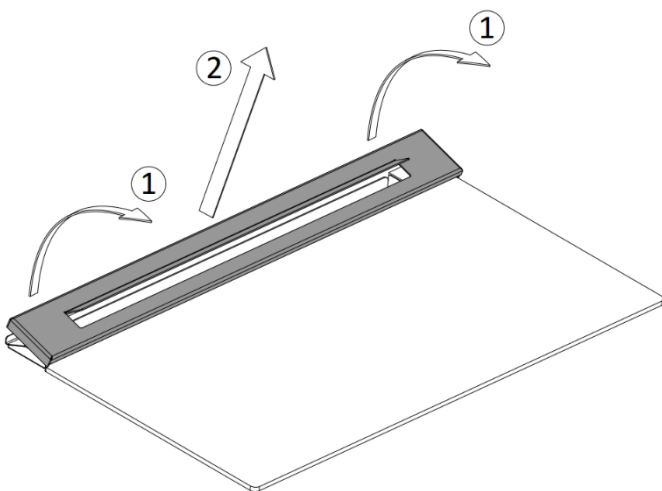

Installing exhaust vent elements



Do not clean the metal elements of the cooktop until they are cold.

Installing the inner exhaust vent element (B)

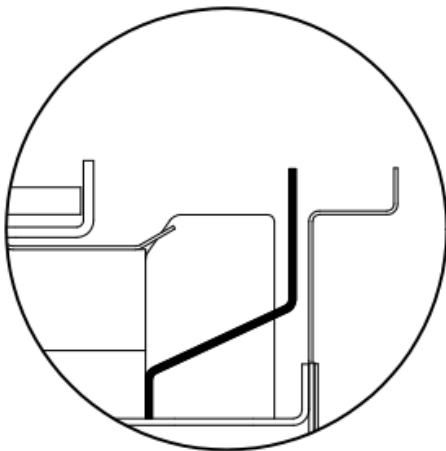
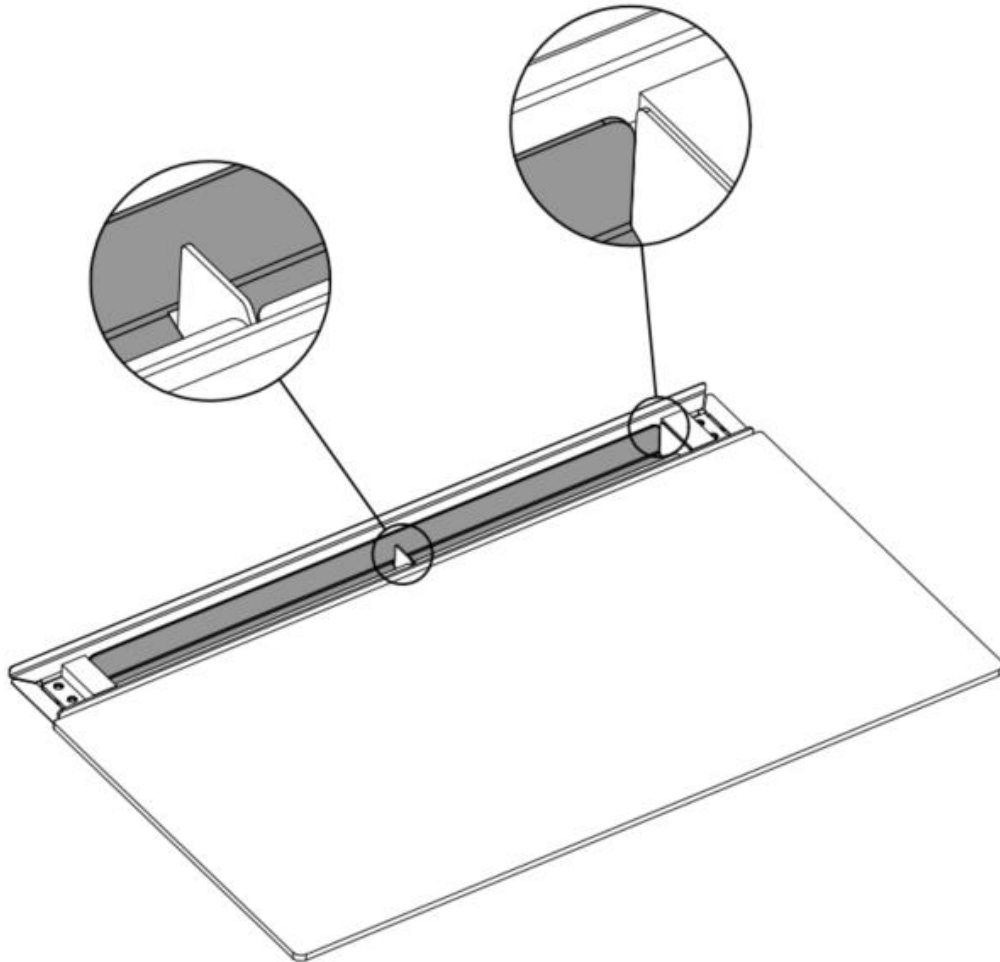

Good

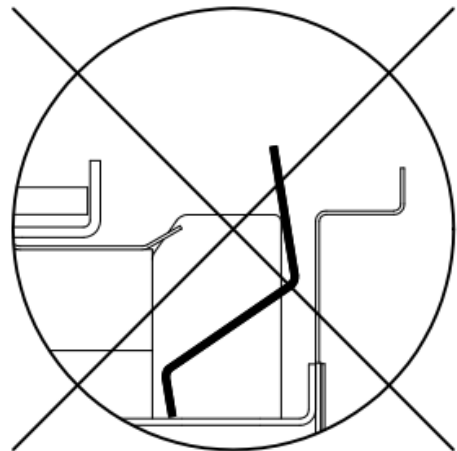

Bad

Installing exhaust vent elements



Do not clean the metal elements of the cooktop until they are cold.

Installing the outer exhaust vent element (A)

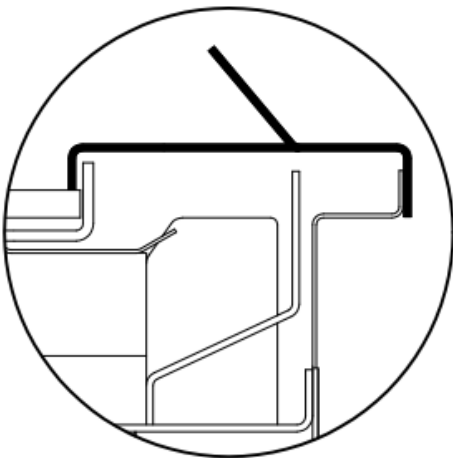
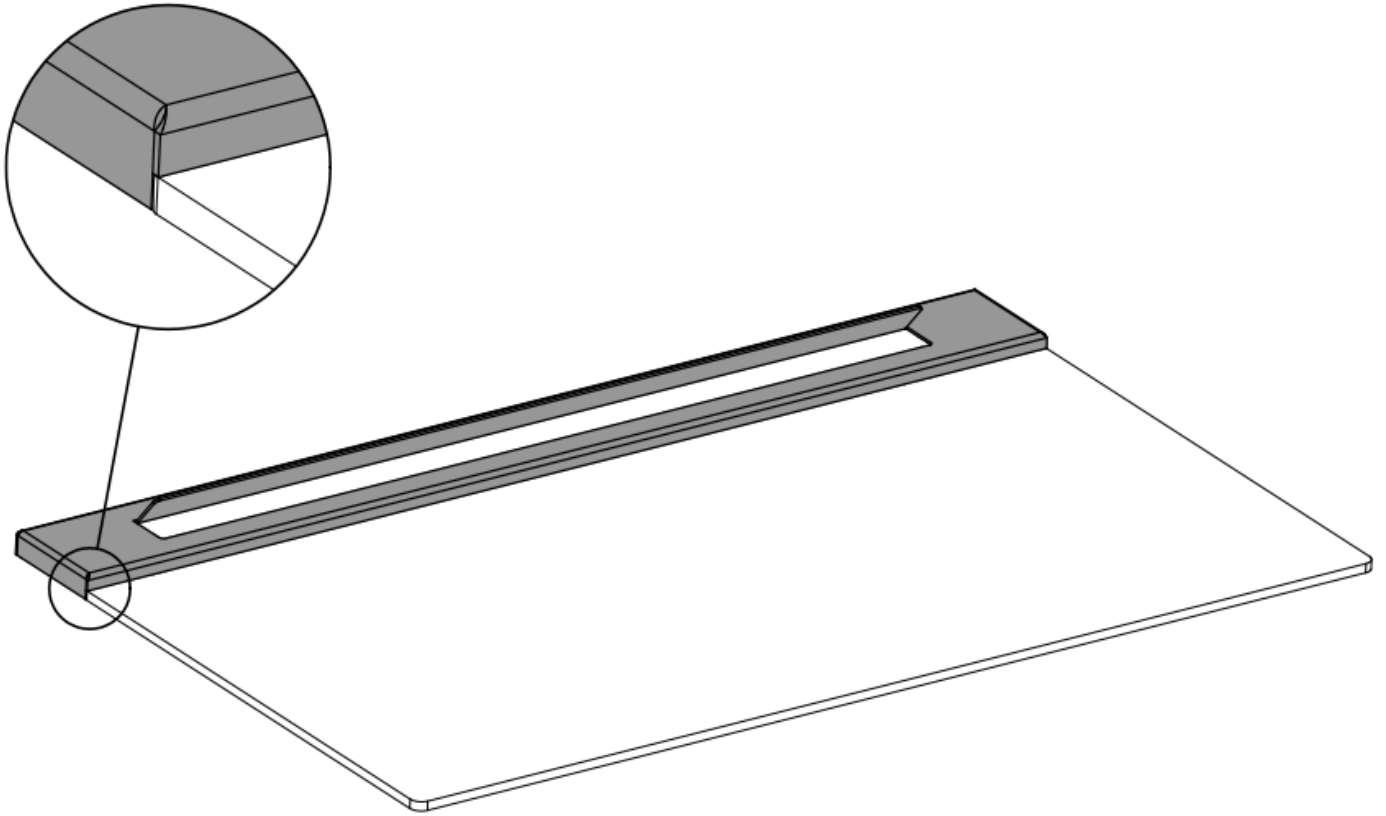

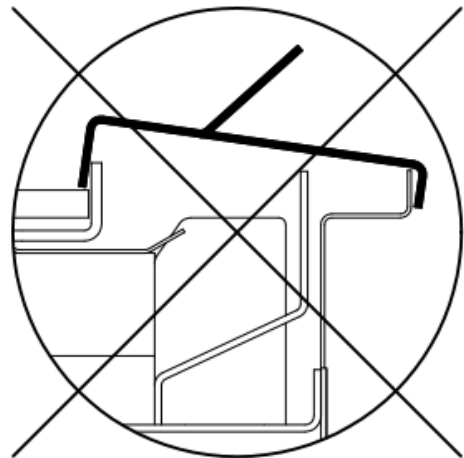

Good



Bad

I. Outer exhaust vent element (A) - cleaning

Contamination type	Cleaning method
<p>1.</p> <p>Light, non-burnt residue, stains</p>	<p>a) if necessary, remove outer exhaust vent element A</p> <p>b) gently wipe off with a wet dish sponge with a little ceramic surface cleaning agent</p> <p>c) wipe dry</p> <p>d) reinstall outer exhaust vent element A</p>
<p>2.</p> <p>Burnt on</p>	<p>a) if necessary, remove outer exhaust vent element A</p> <p><u>INOX (silver) stainless steel outer exhaust element:</u></p> <p>b) apply a little ceramic surface cleaner to the rough scrubbing surface of a dish sponge and apply it to the dirty metal surface. Wait around 5 – 10 minutes and scrub the metal.</p> <div data-bbox="632 790 1453 920" style="border: 1px solid black; padding: 5px;">  <p>Remember to scrub alongside the outer exhaust vent element – in the direction of the polish structure on the outer exhaust vent.</p> </div> <p><u>Outer exhaust element other than INOX, e.g. black:</u></p> <p>a) do not scrub the outer element with a rough fabric, because you may scratch it; apply a ceramic surface cleaning agent to dirty areas and distribute with a cloth/sponge</p> <p>b) wipe off with a wet dish cloth/sponge</p> <p>c) wipe dry</p> <p>d) reinstall outer exhaust vent element A</p>



Make sure that you do not scratch the surface!!!



Do not clean the metal elements of the cooktop until they are cold.

II. Inner exhaust vent element (B) – cleaning







Scrubbing may damage the varnish layer of inner exhaust vent element B, which is why you should avoid scrubbing the element with abrasive materials, the rough side of a sponge, or scrapers.



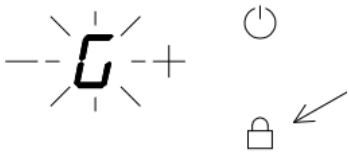

Contamination type	Cleaning method
Stains, residue	<ul style="list-style-type: none"> a) remove outer exhaust vent element A b) remove inner exhaust vent element B c) use a sponge or cloth with a little detergent (dishwashing liquid) to wipe off all residue from the surface of inner exhaust vent element B d) reinstall inner exhaust vent element B e) reinstall outer exhaust vent element A

III. Hot steam vent area - cleaning

Contamination type	Cleaning method
Solid pieces, loose dry goods like flour, groats, rice, etc.	<ul style="list-style-type: none"> a) remove outer exhaust vent element A b) remove inner exhaust vent element B c) use a vacuum cleaner with a soft bristle accessory to gently remove solid pieces from the area of the hot steam vent d) reinstall inner exhaust vent element B e) reinstall outer exhaust vent element A

Troubleshooting. What to do when...

CONTROL PANEL ALARM STATES					
No.	Indication type		Problem	CONDUCT	
	Light	Sound			
1	Flashing or continuous "G" or "G" and "H" interchangeably  with flashing "-" on remaining zones 	Short signal, every 2 sec. until unblocked	No gas supply No flame	<ol style="list-style-type: none"> 1. Make sure that gas is being supplied to the system, e.g. by checking the operating order of other gas-powered appliances. 2. Unblock the ceramic cooktop by touching the sensor marked with the lock symbol (see figure on right) for at least 5 seconds. 3. Try to it turn on three times – with any heating zone power setting sensor. 4. If "G" persists (when you are certain that the gas is being supplied), disconnect the cooktop from the power supply, close the gas valve, and call service assistance. 	
2	Flashing "-" in the display of the given zone 	Continuous 3 sec. signal or continuous signal when touching the sensor	Locked heating zone control module	<ol style="list-style-type: none"> 1. Check whether the control panel area of the ceramic cooktop is clean, e.g. not obstructed by cookware or dirt. Clean it. If the signal persists, follow the guidelines presented below. 2. Turn off the electrical power supply of the cooktop for at least 1 minute. 3. Turn on the electrical power supply of the cooktop. 4. If "-" reappears, call service assistance. 5. In the meantime, you can cook on the other burners. 	
3	Flashing 	Short signal, every 2 sec.	Problem with exhaust vent	<ol style="list-style-type: none"> 1. Turn off the electrical power supply of the cooktop for at least 1 minute. 2. Check for any foreign objects or contamination potentially appearing from the cooktop bottom. 3. Turn on the electrical power supply of the cooktop. 4. If "F" reappears, disconnect the cooktop from the power supply, close the gas valve, and call service assistance. 	

No.	Indication type		Problem	CONDUCT
	Light	Sound		
4	Flashing "U" and "H" 	Short signal, every 2 sec. for 30 sec.	Maximum permitted operating temperature of the cooktop exceeded (overheat)	<ol style="list-style-type: none"> 1. Wait minimum 30 minutes until the cooktop cools off. During this time, the cooktop cannot be activated. 2. Check if the hot air exhaust is not obstructed or clogged up. 3. Check if the outer exhaust vent element (A) and the inner exhaust vent element (B) are properly installed (see section: Installing exhaust vent elements). 4. If "U" persists, disconnect the cooktop from the power supply, close the gas valve, and call service assistance.
5	Continuous "C" 	Short signal, every 2 sec.	Hot exhaust discharge problem	<ol style="list-style-type: none"> 1. Turn off the electrical power supply of the cooktop for at least 5 minutes. 2. Check if the hot air exhaust is not obstructed or clogged up. 3. Check if the outer exhaust vent element (A) and the inner exhaust vent element (B) are properly installed (see section: Installing exhaust vent elements). 4. Turn on the electrical power supply of the cooktop. 5. If "C" reappears, disconnect the cooktop from the power supply, close the gas valve, and call service assistance.
6	Continuous "E" 	Short signal when touching the control sensor	Likelihood of damaged electrical circuit of the cooktop	<ol style="list-style-type: none"> 1. Turn off the electrical power supply of the cooktop for at least 1 minute. 2. Turn on the electrical power supply of the cooktop. 3. If "E" reappears, disconnect the cooktop from the power supply, close the gas valve, and call service assistance.
7	Flashing "t" and "H" 	Short signal, every 2 sec. for 30 sec.	Maximum permitted operating temperature of the cooktop exceeded (overheat)	<ol style="list-style-type: none"> 1. Turn off the electrical power supply of the cooktop for at least 15 minutes. 2. Check if the hot air exhaust is not obstructed or clogged up. 3. Check if the outer exhaust vent element (A) and the inner exhaust vent element (B) are properly installed (see section Installing exhaust vent elements). 4. If "t" reappears, disconnect the cooktop from the power supply, close the gas valve, and call service assistance.

INSTALLATION MANUAL



In order to avoid the risk of potential accidents, it is required that the appliance be installed according to this Manual. The manufacturer is not held liable for any damage resulting from installation of the appliance inconsistently with the Installation Manual. All unauthorised modifications performed in the appliance by the user may be potentially dangerous and are strictly prohibited!



THE USE OF A GAS COOKTOP RESULTS IN THE PRODUCTION OF HEAT, MOISTURE AND PRODUCTS OF COMBUSTION IN THE ROOM IN WHICH IT IS INSTALLED. **ENSURE THAT THE KITCHEN IS WELL VENTILATED ESPECIALLY WHEN THE COOKTOP IS IN USE.**

PROLONGED INTENSIVE USE OF THE GAS COOKTOP MAY REQUIRE ADDITIONAL VENTILATION, FOR EXAMPLE THE INCREASING OF MECHANICAL VENTILATION WHERE PRESENT, ADDITIONAL VENTILATION TO SAFELY REMOVE THE PRODUCTS OF COMBUSTION TO OUTSIDE (EXTERNAL) AIR WHILST ALSO PROVIDING ROOM AIR CHANGES WITH ADDITIONAL VENTILATION. CONSULT A PROFESSIONAL BEFORE INSTALLATION OF THE ADDITIONAL VENTILATION.

Room

- The kitchen space should be dry, airy, and equipped with a natural (gravity) ventilation system discharging the exhaust produced by gas combustion outside. The ventilation system should include a vent grate and/or hood. The room should have a fresh air supply. Fresh air is required for purposes of proper gas combustion. The air can be supplied directly from the ventilation duct inside the room or indirectly from adjacent rooms equipped with ventilation ducts leading outside.
- Hoods are to be installed according to the guidelines specified in their instruction manuals. The minimum recommended distance between the ceramic cooktop and the hood is 650 mm – see figure below.

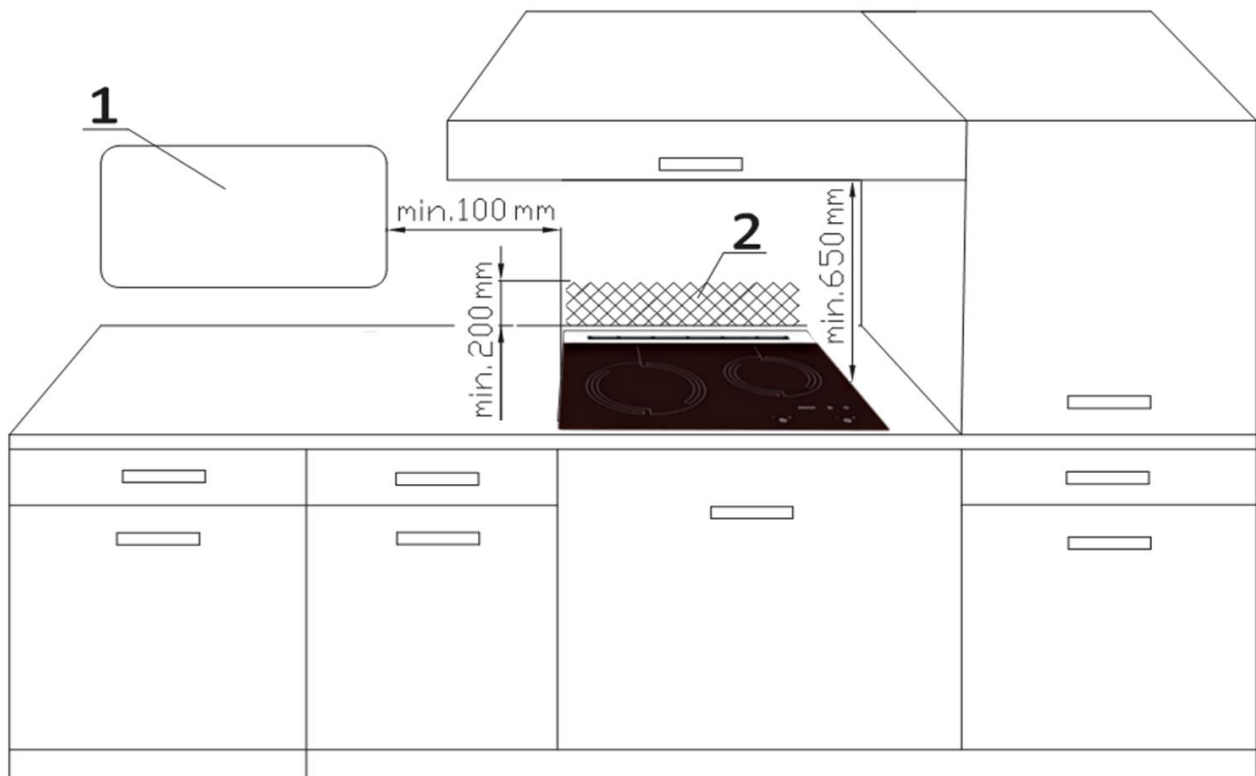

1 – Window



2 – If the distance between the wall and the cooktop is less than 30 mm, thermal insulation of the wall is required (ceramic material is recommended). If you should have any concerns, please contact the DynaCook Servicing Centre.

Installing the ceramic cooktop



Proper operating order of the appliance requires proper installation. If you have any concerns in scope of installing the cooktop in your kitchen furniture, please contact the Service Centre.

tel. +48 606 649 549

e-mail: serwis@dynaxo.pl

www.dynacook.pl

<https://www.dynacook.pl/en/support/>



Use of formable masses (e.g. silicone) to seal the edges of the ceramic cooktop to the counter **is strictly prohibited**. In the event of requiring service repairs, the manufacturer or service point are not responsible for any damage (e.g. damage to the counter surface, damage to the ceramic cooktop) resulting from failing to obey this warning.



Do not install in proximity of flammable materials.

Important guidelines

- The veneer and adhesives of the furniture used to install the cooktop must be resistant to temperatures of minimum 100°C. Failure to fulfil this condition may lead to deformation of the surface or peeling of the veneer.
- The kitchen counter used to install the cooktop must be permanently bolted to the cabinets or permanently joined to the furniture segment.
- Materials on walls (behind the cooktop just outside of the hot air exhaust) must be resistant to temperatures of minimum 80 °C.
- If decorative glass is installed on the wall (behind the cooktop just outside of the hot air exhaust), tempered glass is highly recommended (regular glass may be damaged).
- The cooktop must be connected to a gas network according to the section entitled **Gas system** (this must be done by an authorised gas installation technician, who will confirm connection to the gas network in the Connection Certificate).
- The cooktop must be connected to an electrical power source according to the section entitled **Electrical power supply**.
- After installing the ceramic cooktop in the kitchen counter, please check it for operating order.
- The position of the ceramic cooktop should ensure free access to its control panel.

Cooktop ventilation



In order to ensure that the ceramic cooktop is in proper operating order and does not suffer any damage, you must ensure appropriate ventilation. Installation of the cooktop in cabinets without an appropriate supply of fresh air ensured is strictly prohibited.

- The spaces between the ceramic cooktop and elements of kitchen furniture (e.g. rear cabinet or drawer panel), alternatively between the cooktop and the equipment installed in the same cabinet as the cooktop (e.g. oven), must ensure the air circulation and ventilation required as specified in the Installation Manual.
- For detailed information on the minimum parameters and dimensions required for installation of the cooktop to ensure proper cooktop ventilation depending on the type of the cabinet, please see the figures presented on the following pages of the Installation Manual.

Installation in a cabinet – proper cooktop ventilation must be ensured by fulfilling the requirements specified in the figure presented below.

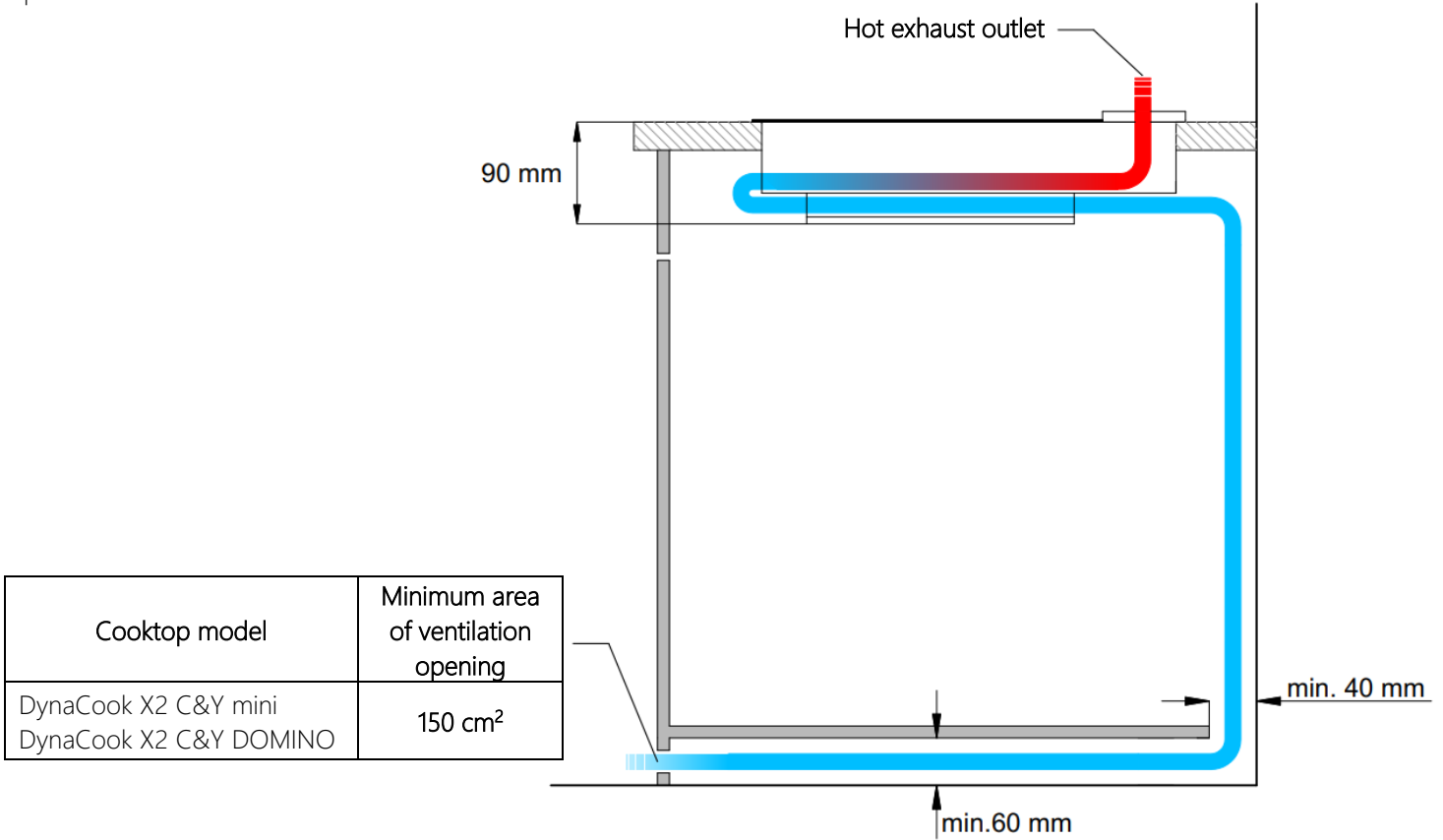

Installation in the counter of a load-bearing cabinet above an oven – proper cooktop ventilation must be ensured by fulfilling the requirements specified in the figure presented below.

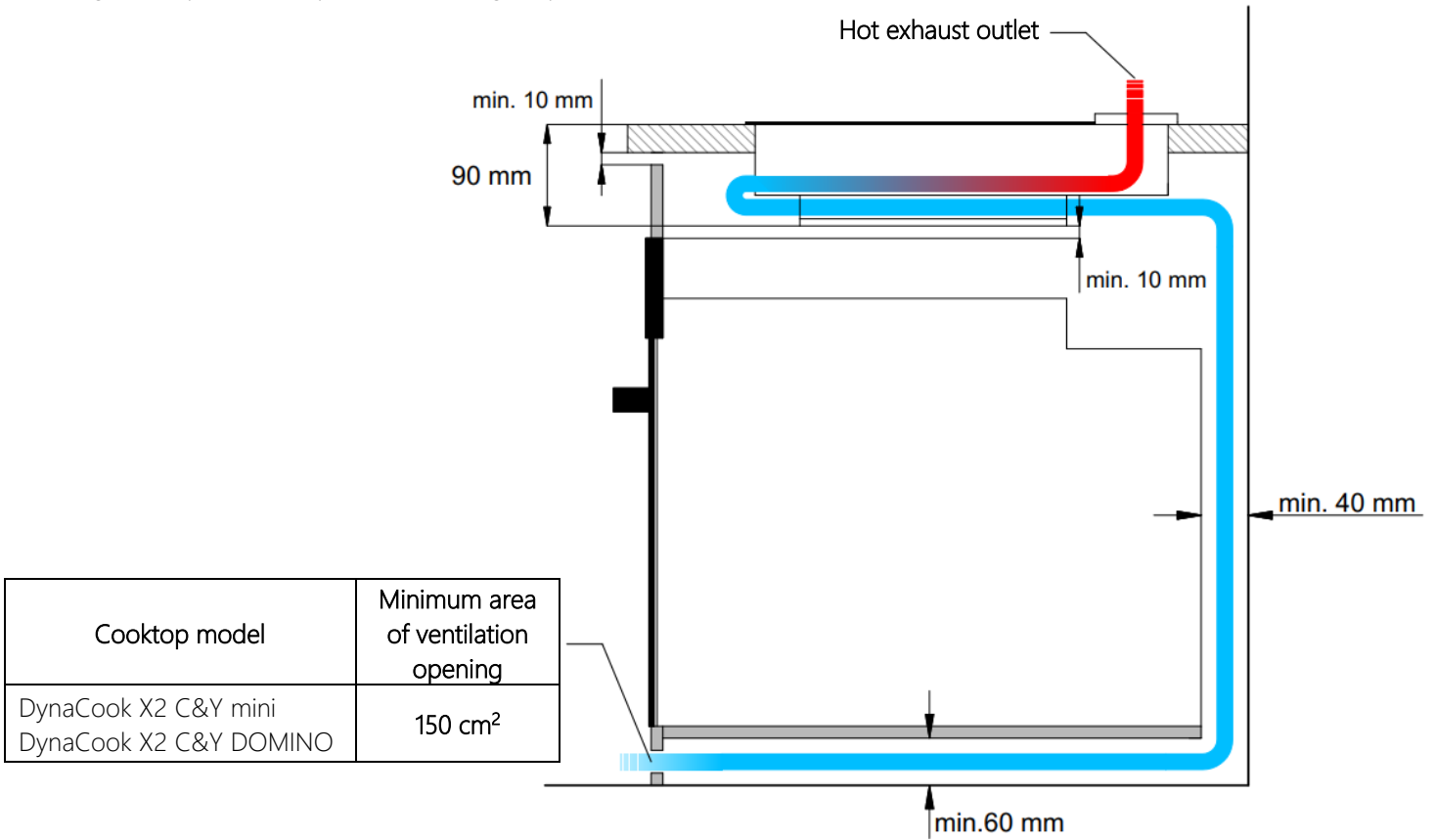

Cutting out the kitchen counter and installing the cooktop in the cutout



The cutout in the counter must be precise. Remember to clean all dust and dirt from the counter.

Step 1: Prepare the point (opening) in the kitchen counter according to the installation diagram:

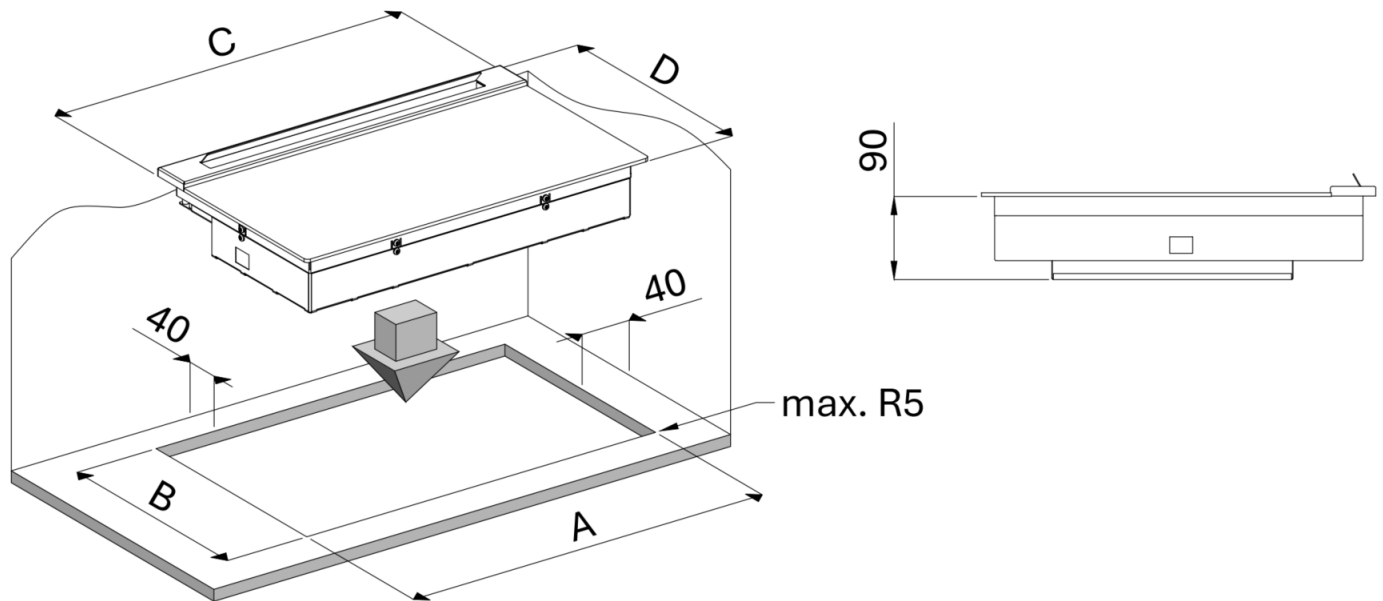

When the distance of the wall to the countertop opening is less than 40 mm, thermal insulation of the wall is required up to 200 mm from the countertop surface (ceramic material is recommended). If you should have any concerns, please contact the DynaCook Servicing Centre.

Cooktop model	COUNTERTOP OPENING		Cooktop dimension	
	Dimension A (+2 mm)	Dimension B (+2 mm)	Dimension C	Dimension D
DynaCook X2 C&Y mini	441 mm	261 mm	460 mm	280 mm
DynaCook X3 C&Y DOMINO	310 mm	480 mm	330 mm	500 mm

Step 2: Secure the cut counter surfaces with varnish **resistant to minimum 100°C and humidity**. Before inserting the cooktop into the cutout in the counter, clean the counter and **apply the attached gasket max. 5 mm** from the edge of the counter cutout.

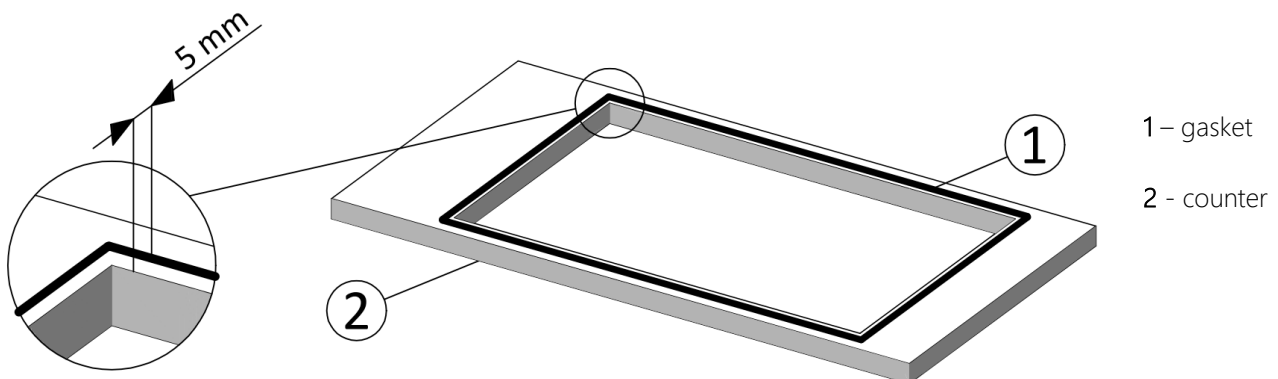

Step 3: Fasten the cooktop to the countertop using **2 pieces** of mounting brackets according to the Manual for mounting brackets for DynaCook cooktop, which is included in the package with the brackets. **The mounting brackets are included in the cooktop package.**

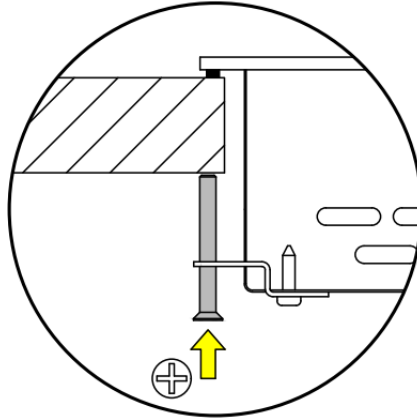

Connect the cooktop to the gas system (see section: **Gas system**) and power supply (see section: **Electrical power supply**). Check for operating order.

Gas system

We are dealing with gas. The ceramic gas cooktop can be connected to an LPG tank or existing gas network **only by a certified gas installation technician** with preservation of all safety standards. The **certified gas installation technician** should connect the ceramic cooktop to the gas system to the type of gas it is configured for by the manufacturer.



The information on the type of gas supported by the cooktop as configured by the manufacturer **can be found on the rating plate of the ceramic gas cooktop.**

The manufacturer is not liable in any way for damage to the ceramic cooktop or other damage resulting from inappropriate gas supply installation, connection of the cooktop to an inappropriate type of gas, connection of the cooktop to poor quality gas, or installation of the cooktop by an individual without valid gas installation authorisations.



Using **propane-butane LPG (G30 3B/P)** in temperatures surrounding the tank and the gas system below +15 °C may cause the cooktop to malfunction. Only **propane (G31 3P)** is permitted when the ambient temperature of the gas tank is below +15°C.



PAY PARTICULAR ATTENTION to make sure that all connections are tight. Following installation of the ceramic cooktop, please check the tightness of all gas connections. Do not use open flame or ammonia solutions to check for gas leaks. It is recommended to perform the gas tightness inspection with a legally certified electronic gas detector. In the event of establishing any leaks, you should immediately close the gas supply valve and effectively remove the leak.

Guidelines for the gas installation technician

The DynaCook ceramic gas cooktop is equipped with a connection line with a \varnothing 8 mm connector to make it possible to connect the cooktop to a gas system in standard RVS 8 (e.g. manufactured by GOK).



The certified installation technician with valid gas installation authorisations fills out and signs the **Connection Certificate** for the ceramic gas cooktop, which is **attached to this Manual (Attachment no. 1)**. A filled out and signed cooktop Connection Certificate serves as grounds to preserve the warranty covering the purchased cooktop.



In order to ensure your safety, to avoid contamination of the internal gas system of the cooktop, and to avoid damage and/or leakiness of the cooktop, the **manufacturer has secured** the gas connector of the DynaCook ceramic gas cooktop with a **cap/seal**.

The only individual authorised to remove the cap/seal is the gas installation technician who is connecting the cooktop to the gas system. **The cap/seal is to be removed just before the cooktop is connected** to the gas supply system and should be confirmed by the installation technician in the cooktop Connection Certificate. If the gas installation technician should determine that the cap/seal of the connector is missing, this fact must be recorded in this Connection Certificate.

The manufacturer is not liable in any way for damage to the ceramic cooktop or other damage resulting from removal of the cap/seal of the gas connector by an unauthorised individual.

The gas installation technician should:

- **Hold valid** gas installation authorisations.
- **Read** the information on the rating plate of the ceramic gas cooktop, specifically in order to learn the type of gas configured in the cooktop by the manufacturer. This information must be compared with the gas supply conditions in the location of installation.

• **Check the following:**

- the cap/seal on the \varnothing 8 mm connector,
- ventilation efficiency, i.e. air exchanges inside the room,
- tightness of the gas fittings.

• **Perform the initial activation**

Following installation of the ceramic cooktop, the gas installation technician must perform the initial activation. When the cooktop is activated for the first time, it may produce momentary “snorting” from the hot air exhaust. This is normal, as it is caused by the air built up in the gas lines and burners. This no longer occurs after the initial activation.

- **Fill out** the Connection Certificate for the ceramic gas cooktop (Attachment no. 1), which can be found in the Warranty Card, **and release it to the user.**

Liquid gas (e.g. propane-butane)



Do not connect the ceramic cooktop to an LPG system in rooms equipped with network gas.



The gas supply line should not come into contact with any metal elements of the casing. The maximum length of the LPG (e.g. propane/butane) flexible hose should not exceed 3 m. In the event of a longer system, you must ensure appropriately-sized gas supply hoses.

The \varnothing 8 mm connector of the cooktop is to be connected with an RVS 8 joint (e.g. manufactured by GOK). A liquid gas regulator with the capacity and output pressure according to the cooktop nameplate is attached to the cylinder valve. All components of the gas installation must have safety certificates.

It is recommended to install a **liquid-phase gas filter** behind the cylinder on the gas installation (for an example of a filter -> see photo opposite), protecting against liquid gas impurities that can contaminate the internal gas installation of the cooktop, clog the nozzles and damage the cooktop.



Electrical power supply



Using a voltage other than 12 V DC to power the cooktop from the vehicle or boat installation may be dangerous to the user, cause damage to the plate and result in the loss of warranty.

The cooktop is supplied with 12 V DC safety voltage directly from the vehicle or boat installation. In order to ensure correct and safe operation of the DynaCook gas ceramic hob, **connect the terminals of the cooktop connection terminal to a 12 V DC electrical system protected by a 4 A fuse** (not included with the cooktop). The diagram of connecting the cooktop directly to the 12 V DC installation of the vehicle or boat is presented in the figures below:

DynaCook X2 C&Y mini

bottom view

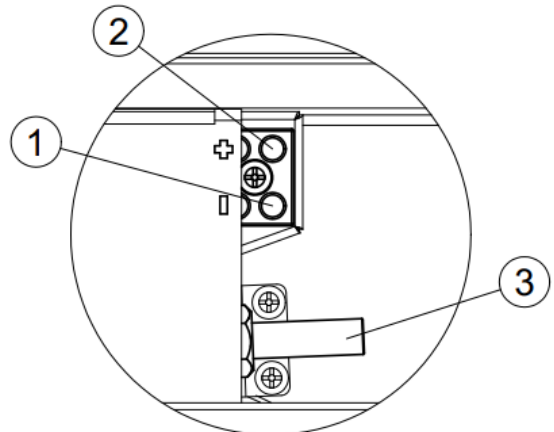
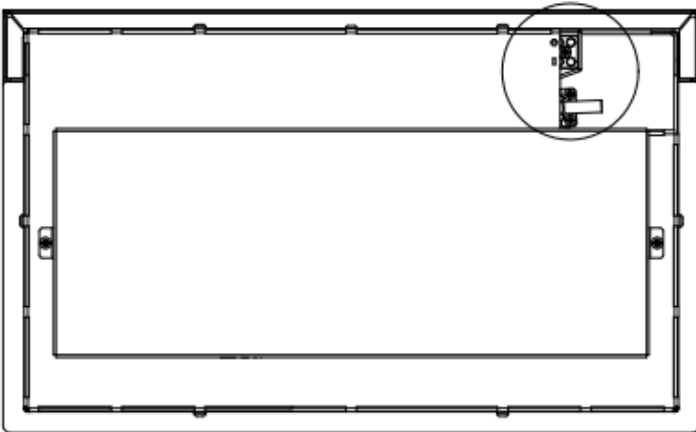

1 - (0 V)

2 + 12 V (DC)

3 Gas connection \varnothing 8 mm

DynaCook X2 C&Y DOMINO

bottom view

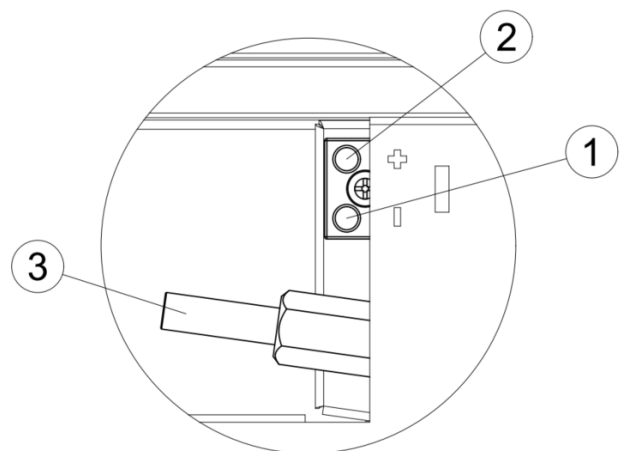
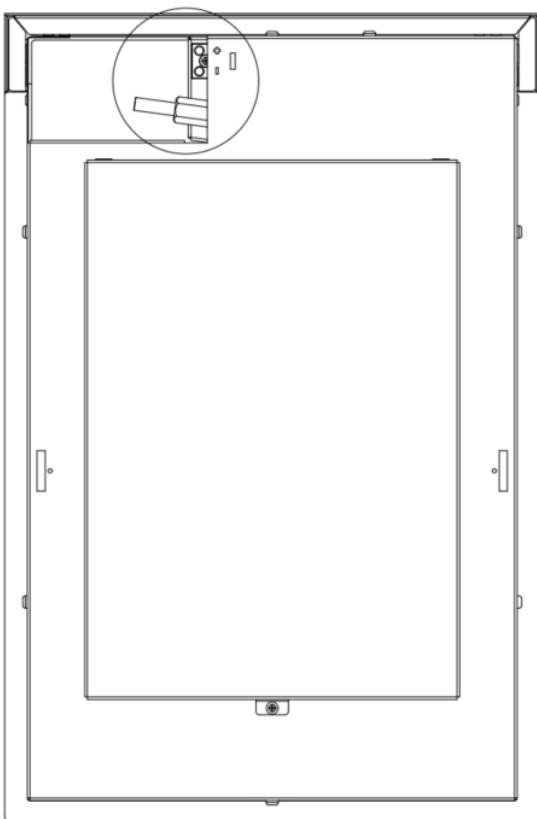

Controlling and monitoring the gas, electrical power, and ventilation systems

In order to ensure proper and safe operating order of the DynaCook ceramic cooktop, you must periodically check the operating order of the gas, electrical power, and ventilation systems, including the following:

- inspecting the technical condition of the aforementioned systems,
- reporting concerns to the vehicle/boat owner or administrator the event of establishing any inconsistencies in the technical condition of the aforementioned systems.

Converting the cooktop to a different type of gas

The information on the type of gas supported by the cooktop according to the configuration of the manufacturer can be found on the rating plate of the ceramic cooktop. Due to the design, every cooktop is configured by the manufacturer to a specific type of gas. **The Customer should provide information on the type of gas intended to be used when placing the order for the cooktop.** If the need to convert the cooktop to a different type of gas should arise, please contact the **Service Centre**:

tel. +48 606 649 549

e-mail: serwis@dynaxo.pl

www.dynacook.pl

<https://www.dynacook.pl/en/support/>

in order to arrange the terms for converting the cooktop to a type of gas other than that specified in its rating plate.



Converting the gas configuration by a service provider not authorised by the manufacturer is dangerous to the user, prohibited, and voids the warranty of the cooktop.

TECHNICAL DATA

Rated thermal loads of burners for various gases		
Gas	G30 (3B/P)	G31 (3P)
Pressure [mbar]	30	30
Small burner (S)	1,10	1,00
Medium burner (M)	1,80	1,60

Rated thermal loads of DynaCook cooktops			
	Gas	G30 (3B/P)	G31 (3P)
Cooktop model	Pressure [mbar]	30	30
DynaCook X2 C&Y mini	(S+M)	2,90 kW	2,60 kW
DynaCook X2 C&Y DOMINO	(S+M)	2,90 kW	2,60 kW

Gas consumption [g/h]			
	Gas	G30 (3B/P)	G31 (3P)
Cooktop model	Pressure [mbar]	30	30
DynaCook X2 C&Y mini	(S+M)	210 g/h	185 g/h
DynaCook X2 C&Y DOMINO	(S+M)	210 g/h	185 g/h

Technical parameters of DynaCook cooktops							
Cooktop model	Gas category	Dimensions [mm] width x depth x height	Weight [kg]	Gas connection	Supply voltage	Casing protection degree	Working temperature
DynaCook X2 C&Y mini	I3PB/P	460 x 280 x 90	5,20	ø 8 mm	12 V DC	IP40	5 - 40 °C
DynaCook X2 C&Y DOMINO	I3PB/P	330 x 500 x 90	6,60	ø 8 mm	12 V DC	IP40	5 - 40 °C



**MADE IN POLAND
2020**

Thank you for choosing DynaCook

DYNAXO®

Manufacturer of gas ceramic hobs DynaCook

DYNAXO Sp. z o.o.
Popowo 2A
64-510 Wronki
www.dynaxo.pl

Need support? You can find it here:

DynaCook Service Centre
tel. +48 606 649 549
E-mail: serwis@dynaxo.pl
www.dynacook.pl

<https://www.dynacook.pl/en/support/>

